

Victorian Recreational Boating Safety Handbook

November 2011

FREE



www.transportsafety.vic.gov.au

A Victorian
Government
initiative



© Director, Transport Safety, Australia, 2011

ISBN 0 7311 8737 7

Copyright in this publication resides with the Director, Transport Safety and the State of Victoria. No part of this publication may be reproduced by any process except in accordance with the provisions of the *Copyright Act 1968* (Cth).

This handbook contains information on the legal requirements for operators of recreational vessels. It is intended as a guide only, and is not a substitute for the relevant legislation. Laws relating to the operation of recreational vessels change from time to time. Tests may change accordingly. If you have questions about this handbook check with any of the VicRoads Customer Service Centres listed at the back of this handbook, or Transport Safety Victoria on 1800 223 022.

For a complete knowledge of marine safety legislation and waterway rules, you should consult the *Marine Act 1988* (Vic) and associated regulations and notices published in the Government Gazette. Copies of Victorian Legislation and Parliamentary Documents, are provided online at www.legislation.vic.gov.au or can be purchased from the Information Victoria Bookshop.

This publication is distributed free by Transport Safety Victoria.

About Transport Safety Victoria

Transport Safety Victoria (TSV) is a newly established, independent statutory office that regulates the safety of all bus, maritime and rail operations in Victoria. It is an outcome of the *Transport Integration Act 2010* (Vic), which merged the former Marine Safety Victoria and Public Transport Safety Victoria on 1 July 2010.

TSV's objective is to independently seek the highest transport safety standards that are reasonably practicable, in accordance with relevant legislation. We are committed to achieving safe bus, maritime and rail transport for the benefit of all Victorians.

The Maritime Safety Branch aims to improve safety outcomes by regulating the operation of commercial and recreational vessels and ensuring a safe environment for their navigation on Victorian waters. Maritime Safety regulates through certification, education, safety management plans and safety audits and compliance activities, underpinned by positive links with the maritime industry, including port and waterway managers.



Contact us

Transport Safety Victoria

121 Exhibition Street, Melbourne, Victoria
PO Box 2797, Melbourne, Victoria, 3001

T. 1800 223 022

F. +61 3 9655 8929

E. marinesafety@transportsafety.vic.gov.au

W. www.transportsafety.vic.gov.au

The new Marine Safety Act will affect you

The *Marine Safety Act 2010* (Vic) will come into full effect in 2012. You will have responsibilities under the Act that you need to be aware of if you are:

- an owner of a vessel
- a person who designs, commissions, manufactures, supplies, installs, maintains, repairs or modifies vessels, marine safety equipment or marine safety infrastructure
- a marine safety worker
- otherwise involved in recreational boating activities (as a master, operator or passenger)
- a member of the public.

Make sure you understand your safety obligations. Go to www.transportsafety.vic.gov.au for more information and to subscribe to our email alerts.

NAVIGATE THE NEW MARINE SAFETY ACT

Contents

About Transport Safety Victoria	i
Introduction	1
Marine Act and Regulations	1
Recreational boat operator licensing	1
Types of licence	1
Operating without a licence.....	2
Obtaining a licence	2
No prior qualifications	2
How to book a test	3
Interstate licence holders	3
TSV approved training providers.....	4
Marine qualification holders	4
Proof of identity.....	4
Vessel registration requirements	5
Registration labels and identification marks	5
Hire and drive requirements	5
USEFUL LINKS	90
VICROADS CUSTOMER SERVICE CENTRES	92
Trading hours	92
All telephone enquiries	92
Metropolitan offices	92
Country offices	93

CHAPTER 1. TRIP PREPARATION

CHAPTER 2. SAFE OPERATION

CHAPTER 3. EMERGENCY PROCEDURES

CHAPTER 4. PERSONAL WATERCRAFT (PWC)

Definitions	6
Maps showing coastal, enclosed and inland waters within Victoria	8
Before you go boating	14
Maintenance notes.....	14
Pre-start check list.....	15
Let someone know before you go	16
Safe loading	16
Minimum safety equipment	17
Exemptions and maintenance.....	17

Boat handling	42
Steering and sailing rules.....	42
Steering and sailing rules – restricted visibility....	44
Fishing vessels.....	44
Responsibilities between vessels	44
Large vessels	45
Anchoring.....	45
Launching	46
Retrieving.....	46
Harbourmaster's directions.....	46

Reporting incidents and accidents	74
Coping with emergencies	74
Man overboard.....	76

Registration.....	82
Operator licensing	83
Education	83
Keep your distance.....	83

Requirements for mechanically powered vessels ...	18	Compass	27	Safety hints	33
Requirements for sail and human powered vessels .	19	Anchors.....	27	Crossing ocean bars	34
Personal Flotation Devices (PFDs).....	20	Marine radio.....	27	Shipping operations	35
Is your PFD legal?	22	Local knowledge	29	Environmental and wildlife regulations	36
What type of PFD must I wear?	23	Marine weather information	30	Marine national parks and marine sanctuaries	37
PFDs on children.....	23	Physical hazards and conditions	30	Restrictions	37
Fire	24	Weather	30	Boundary markers.....	38
Fire protection	24	Wind	31	Environment protection	38
Distress flares.....	25	Waves	32	Colour coded berthing zones	38
EPIRBs	26	Thunderstorms.....	33	Sample test questions	39
Navigation.....	47	Cardinal marks.....	52	Sailboats and rowing boats.....	58
Operating rules	48	Special marks	53	Powerboats	59
Speed restrictions	48	Isolated danger marks.....	54	Larger vessels.....	60
General safety/Operating rules	49	Safe water marks.....	54	Dayshapes for vessels	64
Alcohol and drugs	50	Zone signage	56	Sound and light signals	67
Buoyage system	50	Inland waters	56	Definitions and classifications	67
Ports and coastal waters.....	50	Coastal and inland waters.....	57	Conduct of vessels in restricted visibility	68
Direction of buoyage	50	Onshore beacons	57	Waterskiing	70
Buoyage types	51	Navigation lights	57	Hand signals	70
Lateral marks.....	51	Minimum visibility for length of vessel	57	Sample test questions	71
First aid afloat	76	Distress signals	78	Sample test questions	80
Hypothermia.....	76	Abandoning vessel	79		
Bleeding.....	77	Rescue by helicopter	80		
Burns	77				
Seasickness	77				
Exposure to the sun	78				
Noise.....	83	Avoiding accidents	84	Sample test questions	86
Safety equipment.....	84	Safety first	85		
Waterskiing	84	Penalties	85		
Safe speed.....	84	What does it mean to be a safe and courteous rider?	85		

TRIP PREPARATION



PROPERLY MAINTAIN YOUR VESSEL, ENGINE AND SAFETY EQUIPMENT



CHECK THE MARINE WEATHER REPORT



ENSURE YOU HAVE SUFFICIENT FUEL AND RESERVE FUEL



FULLY CHARGE YOUR BATTERIES



INFORM A PERSON OF YOUR TRIP INTENTIONS



A BOAT LICENCE IS REQUIRED TO OPERATE A RECREATIONAL POWER BOAT IN VICTORIA

SAFE OPERATION



MAXIMUM SPEED

- WITHIN 50 M OF SWIMMERS, OTHER VESSELS AND FIXED OR FLOATING STRUCTURES
- WITHIN 100 M OF DIVERS/DIVERS' FLAG



- WITHIN 50 M OF WATER'S EDGE (INLAND)
- WITHIN 200 M OF WATER'S EDGE (COASTAL AND ENCLOSED)



DON'T DRINK AND BOAT

- .00 BLOOD ALCOHOL LIMIT APPLIES FOR UNDER 21 AND SUPERVISOR
- .05 BLOOD ALCOHOL LIMIT APPLIES FOR OVER 21



MAINTAIN A GOOD LOOKOUT AND OPERATE AT A SAFE SPEED

EMERGENCY PROCEDURES



ALL OCCUPANTS TO PUT ON PFDs

RAISE THE ALARM



- **MARINE RADIO**
27MHz – Ch 88
VHF – Ch 16



- **FLARES**
Activate when you see a potential rescuer



- **PHONE**
Call 000



- **EPIRB**
Activate your distress beacon

STAY WITH YOUR BOAT



- A vessel is a lot easier to spot than a swimmer
- Anchor your boat to maintain position (if safe to do so)

Only digital 406MHz EPIRBs will be detected by satellite from 1 February 2009. Analogue 121.5MHz EPIRBs will not be detected. Switch to 406 when the battery on your current beacon expires.

Introduction

About this handbook

This handbook provides information on the requirements for operating a recreational vessel in Victoria. It is recommended reading for all existing and intending operators of recreational vessels and should be retained as a valuable reference.

Marine Act and Regulations

All vessels operating in Victorian waters are required to comply with the relevant provisions of the following documents:

Marine Act 1988 (Vic)

Marine Regulations 2009 (Vic)

Vessel Operating and Zoning Rules

Local Port Rules & Harbour Master's Directions

Copies of Victorian Legislation and Parliamentary Documents, are available from (www.legislation.vic.gov.au) or can be purchased from the Information Victoria Bookshop. Vessel Operating and Zoning Rules are available online (www.transportsafety.vic.gov.au).

Recreational boat operator licensing

All boat operators require a licence to operate a powered recreational vessel in Victoria. The *Marine Act 1988* states that:

- any person who operates a registered recreational powerboat must have a licence
- operators of personal watercraft (PWCs) must have their licence endorsed accordingly
- valid interstate licences will be automatically recognised in Victoria.

Types of licence

General Boat Operator Licence

A general boat operator licence is required by any person over the age of 16 who is operating a powered recreational vessel.

Restricted Operator Licence

A restricted boat operator licence is required by any person over the age of 12, but under the age of 16, who is operating a powered recreational vessel.

Restricted Operator Licence conditions

Holders of a restricted operator licence:

- a. must operate at speeds of less than 10 knots
- b. may operate at speeds of up to 20 knots if:
 - i. accompanied by a person over the age of 16 years who is licensed appropriately for the vessel being operated
 - ii. operating between sunrise and sunset

(For example, if a PWC is being operated, the licence of the accompanying person must be endorsed for PWC operation)

- c. must not operate a vessel that is towing.

Once a restricted operator turns 16, the restricted licence automatically becomes a general boat operator licence.

Please note – it is illegal for persons under the age of 12 years to operate a powered recreational vessel.

PWC endorsed licence

Operators of PWCs must obtain an endorsement on their general boat operator licence or restricted boat operator licence in order to operate a PWC.

Operating without a licence

A person must not operate a registered recreational powerboat unless:

- a. the person is the holder of a licence that authorises the person to operate such a vessel
- b. the person operates the vessel under and in accordance with the licence.

A person must not operate a PWC unless:

- a. the person is the holder of a licence that:
 - i. authorises the person to operate a recreational powerboat
 - ii. is endorsed to authorise the person to operate a PWC
- b. the person operates the PWC under and in accordance with the licence and endorsement.

Please note – any person operating a powered vessel must carry their licence at all times.

Obtaining a licence

No prior qualifications

The Victorian Recreational Boating Safety Handbook explains the main rules and regulations which apply to all boat operators and must be understood prior to undergoing the boat operator licence test at any VicRoads Customer Service Centre.

PWC operators will need to study all chapters of this handbook before making a booking. A separate PWC endorsement test is required in addition to the boat operator licence test (only one test fee applies if both tests are booked in for the same day).

What is involved in the test?

- an eyesight chart to test vision
- a multiple-choice test to assess knowledge of waterway rules and safe boat operation.

The minimum passing grade for the boat operator licence test, is 26 out of 30 questions.

The minimum passing grade for the PWC endorsement test is 13 out of 15 questions.

All test questions are based on Chapters 1, 2, 3 and 4 of this handbook.

Language options

When you sit for your boat operator licence test or your PWC endorsement test, you may choose to do the test in any of the following languages:

Arabic	Chinese (simplified)	English
Turkish	Vietnamese	

Please contact TSV on 1800 223 022 regarding multilingual handbooks. Please contact VicRoads on 13 11 71 if an interpreter in any language is required or for assistance for those who are hearing impaired.

How to book a test

Applicants must be at least 12 years of age before they can attempt the Restricted Operator Licence test and at least 16 years of age to attempt the General Boat Operator Licence test.

An applicant can book for the boat operator licence and/or PWC endorsement test in person or by telephone. Please note, test fees do apply.

When booking a test, an applicant will be asked personal details such as name, date of birth and address. Depending on availability, an applicant can nominate when and where they would like to be tested. Each applicant will be given an appointment number, which is to be presented to the VicRoads officer who conducts the test.

Note: Applicants wishing to cancel an appointment must give the testing offices at least 24 hours notice. Otherwise fees will not be refunded unless a medical certificate or other supporting evidence is produced.

To book by telephone

Please note that the applicant will be required to pay for the test at the time of making the appointment by providing credit card details.

- National calls: 13 11 71
- International calls: +61 3 9854 2666
- Impaired hearing or speech, and use a telephone typewriter (TTY): 1300 652 321.

To book in person

Go to any of the VicRoads Customer Service Centres listed at the back of this handbook and pay for the test at the time of booking.

Annual licence fees

For information on fees please contact VicRoads.

Interstate licence holders

Victorian residents holding an interstate licence must convert to a Victorian boat operator licence. Licence holders can take their existing licence, along with appropriate proof of identity, to a VicRoads Customer Service Centre (annual licence fees apply).

TSV advises all Victorians who travel interstate to familiarise themselves and comply with local waterway regulations.

Interstate visitors

Interstate visitors who hold an interstate boat operator licence, restricted boat operator licence or PWC endorsed licence, are able to operate the equivalent vessel in Victoria for a period of three months. If the operation of the vessel extends beyond three months or the visitor does not have an equivalent interstate licence for the vessel they wish to operate, then a Victorian licence must be obtained.

Interstate visitors are required to observe Victorian regulations including speed restrictions and the wearing of Personal Flotation Devices (PFDs) at certain times. An exemption applies for visiting vessels for the carriage of safety equipment – see page 17 for further detail.

TSV approved training providers

Approved boating safety training courses are valid for six months and are listed on the TSV website (www.transportsafety.vic.gov.au) or can be obtained by telephoning TSV on 1800 223 022.

Operators who have completed an TSV approved boating safety training course may apply for a licence consistent with the course completed without sitting a licence test. To obtain a Victorian boat operator licence operators must take their certificate of completion along with appropriate proof of identity (an annual licence fee applies) to VicRoads. New applicants are required to read an eyesight chart to test vision.

Marine qualification holders

Holders of valid certificates of competency such as a Coxswain, Skipper, Master or Mate issued by a State or Commonwealth marine authority, or other qualifications approved by TSV, may apply for a general licence without sitting a licence test. To obtain a Victorian boat operator licence, these operators must take their certificate, along with appropriate proof of identity (an annual licence fee applies) to VicRoads. New applicants are required to read an eyesight chart to test vision.

Proof of identity

Before a boat operator licence, restricted operator licence, or PWC endorsement can be issued, an applicant must provide one primary and one secondary document giving proof of identity. Additional documentation may be required if the documents are not in English or if documents show different names. The original documents should be presented.

Refer to any VicRoads Customer Service Centre or the VicRoads website (www.vicroads.vic.gov.au) for details of acceptable proof of identity.



If visiting VicRoads, use this checklist:

- Appointment number (if a booking was made)
- Proof of identity and age (see section on 'Proof of identity')
- Certified copies of any certificates or interstate licences for the purposes of exemption from the boat operator licence or PWC endorsement test
- Payment for the boat operator licence and/or PWC endorsement

Applicants with poor vision:

- An eyesight certificate from an optometrist or ophthalmologist

Applicants with a disability or illness that may affect the ability to operate a vessel:

- A medical report from a doctor stating the applicant is medically fit to operate a vessel

Contact VicRoads for further information.

A licence holder must tell VicRoads if they develop any medical condition that might affect the safe operation of a vessel.

Vessel registration requirements

The owners of recreational vessels equipped with an engine that is capable of being used for propulsion are required to register their vessel with VicRoads, acting as an agent of TSV. Details of individual registration requirements can be obtained from:

VicRoads – 13 11 71 or www.vicroads.vic.gov.au

TSV – 1800 223 022 or www.transportsafety.vic.gov.au

Registration labels and identification marks

The registered owner or operator of a recreational vessel must ensure that the registration label issued by VicRoads on behalf of TSV is affixed and remains affixed in a conspicuous position on the outside or upper position of the vessel.

The registered owner or operator of a vessel must ensure that the identification mark that is assigned by TSV for that vessel is painted or displayed on the hull of the vessel on each side of the bow as high as practicable above the waterline in characters that are:

- no less than 150 mm high (or 100 mm on a PWC)
- in proportionate breadth
- coloured in contrast to that of the surface on which they are displayed
- Recreational tenders are required to display the name of its mother ship or the registration number of that vessel and the letter "T".

Hire and drive requirements

An operator of a hire and drive vessel will require a licence to hire that vessel in Victoria if they:

- are 12 years of age or over, but under 16
- are hiring a PWC
- are hiring a boat capable of a speed greater than 10 knots (18 km/h).

The hire boat owner should advise clients on the individual capability of each specific vessel.

CHAPTER 1. TRIP PREPARATION

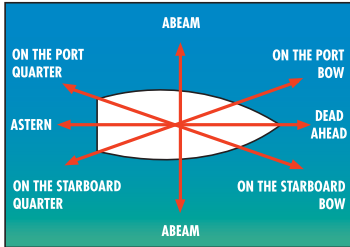

Definitions

Term	Meaning
Abaft	A nautical term meaning towards the stern
Abeam	Abreast of or at right angles to the fore and aft line of the vessel
Aft	Towards the stern or rear of the vessel
Astern, to go astern	Go backwards, put the engine in reverse
Bow	The front end of the vessel
Distance	Where 'miles' are referred to in this booklet 'nautical' miles are meant One nautical mile = 1.852 km
EPIRB	Emergency Position Indicating Radio Beacon
Give way	Slow, stop, go astern or change course to keep clear of another vessel
Gunwales	The top edge of a vessel's side (pronounced gunnels)
Heave to	Steering into the wind and sea making minimum headway
Knot (1)	One nautical mile an hour; 1.852 km/h
Leeward	The side opposite to that from which the wind blows
Making way	Vessel under way and moving through the water, using power or sail

PWC Any recreational vessel that is of a kind that is required to be registered and that:

- is power driven
- has a fully enclosed hull
- does not retain water on it if it capsizes
- is designed to be operated by a person standing, sitting astride or kneeling on the vessel, but not seated within the vessel.

PFD	Personal Flotation Device
Port side	Looking forward, the left-hand side
Recreational tender	A vessel, other than a personal watercraft that: <ol style="list-style-type: none"> does not exceed 4.8 metres in length is used, or that is intended to be used, as a means of transportation but not for towing conspicuously displays the name of its mother vessel or the registration number of that vessel and the letter 'T' operates or is intended to operate: <ol style="list-style-type: none"> between the shore and another recreational vessel that is no more than 300 metres from the shore and no more than 300 metres from the point of its entry to the water between recreational vessels that are no more than 300 metres apart.
Speed	All speeds are measured in 'knots' One knot = 1 nautical mile per hour
Standards	All equipment referred to in this document must meet standards detailed under the <i>Marine Act 1988</i> and its associated Regulations and schedules.
Starboard side	Looking forward, the right-hand side
Stem the tide	Go forward against the current
Stern	The back end or rear of a vessel

Under way	Not at anchor, made fast to the shore, or aground. If you are drifting you are under way
Wash	Waves made by a vessel making way
Windward	The direction from which the wind blows (upwind)

Definitions of waterways

The following definitions of waterways have been adopted to provide guidance regarding the **minimum** safety equipment that you are required to carry.

Note: The operator of a recreational vessel should undertake a safety assessment of the particular vessel and its intended operation. In addition to the minimum safety equipment carried in accordance with the regulations, the vessel should carry any other additional safety equipment that may be appropriate to control risks to acceptable levels.

Inland waters:	<p>(a) All inland waters including rivers, creeks, canals, lakes, reservoirs, etc. either naturally formed or man-made and which are privately or publicly owned.</p> <p>(b) The Yarra and Maribyrnong Rivers (upstream of the port).</p>
Enclosed waters:	<p>(a) The waters inside the seaward entrance of the ports of Apollo Bay, Anderson Inlet, Gippsland Lakes, Snowy River, Mallacoota, and Port Fairy.</p> <p>(b) The waters of the Port of Barwon Heads upstream of the Barwon Heads-Ocean Grove road bridge.</p> <p>(c) The waters of the Port of Corner Inlet and Port Albert east of a line between Port Welshpool shipping pier and Bentley Point (inside the entrances).</p> <p>(d) The waters of Shallow Inlet.</p> <p>(e) The port waters (inside the entrance) of the Port of Portland.</p>

- (f) The waters of Port Phillip Bay landward of an imaginary line drawn between Point Lonsdale and Point Nepean as shown on the chart AUS 144 'Approaches to Port Phillip', published by the Hydrographic Service, Royal Australian Navy, 9 November 2001.
- (g) The waters of Western Port landward of its western entrance joined by an imaginary line drawn between West Head to the southern tip of Seal Rocks to Point Grant and landward of its eastern entrance joined by an imaginary line drawn between Cape Woolami and Griffith Point as shown on the chart AUS 150 'Western Port', published by the Hydrographic Service, Royal Australian Navy, 22 March 1995.
- (h) The waters between the seaward entrance of Tamboon Inlet and the northerly boundary of an imaginary line drawn between Flanders track and the creek on the eastern side of the Inlet.
- (i) The waters between the seaward entrance of Wingan Inlet and the northerly boundary of an imaginary line drawn between Rocky Creek and the bank directly opposite to the west.
- (j) The waters between the seaward entrance of Sydenham Inlet and the mouth of the Bemm River.

Coastal waters:	All other waters along the Victorian coastline.
------------------------	---

Maps showing coastal, enclosed and inland waters within Victoria

Refer to p. 18 to identify safety equipment requirements for these waters.



Coastal waters



Enclosed waters



Inland waters



- Strong tides, currents and dangerous waves may exist where enclosed waters meet coastal waters
- Enclosed waters sealed off from coastal waters may break out causing extremely dangerous conditions
- An anchor and flares must be carried when boating in enclosed waters
- Check conditions prior to departure.

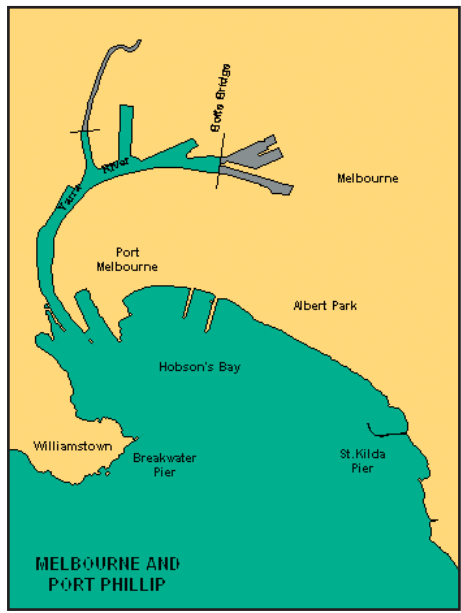

Coastal waters



Enclosed waters



Inland waters



- Strong tides, currents and dangerous waves may exist where enclosed waters meet coastal waters
- Enclosed waters sealed off from coastal waters may break out causing extremely dangerous conditions
- An anchor and flares must be carried when boating in enclosed waters
- Check conditions prior to departure.

Maps showing coastal, enclosed and inland waters within Victoria

Refer to p. 18 to identify safety equipment requirements for these waters.



Coastal waters



Enclosed waters



Inland waters



- Strong tides, currents and dangerous waves may exist where enclosed waters meet coastal waters
- Enclosed waters sealed off from coastal waters may break out causing extremely dangerous conditions
- An anchor and flares must be carried when boating in enclosed waters
- Check conditions prior to departure.



Coastal waters



Enclosed waters



Inland waters



- Strong tides, currents and dangerous waves may exist where enclosed waters meet coastal waters
- Enclosed waters sealed off from coastal waters may break out causing extremely dangerous conditions
- An anchor and flares must be carried when boating in enclosed waters
- Check conditions prior to departure.

Maps showing coastal, enclosed and inland waters within Victoria

Refer to p. 18 to identify safety equipment requirements for these waters.

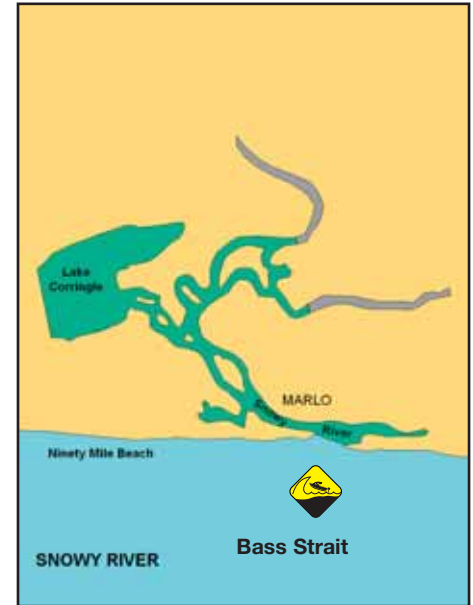

Coastal waters



Enclosed waters



Inland waters



- Strong tides, currents and dangerous waves may exist where enclosed waters meet coastal waters
- Enclosed waters sealed off from coastal waters may break out causing extremely dangerous conditions
- An anchor and flares must be carried when boating in enclosed waters
- Check conditions prior to departure.

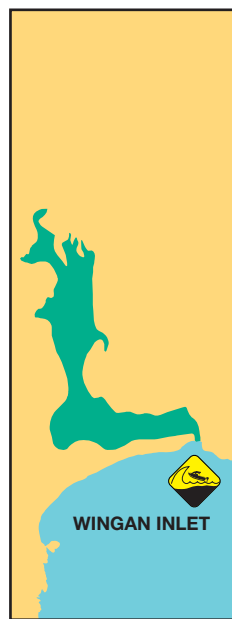
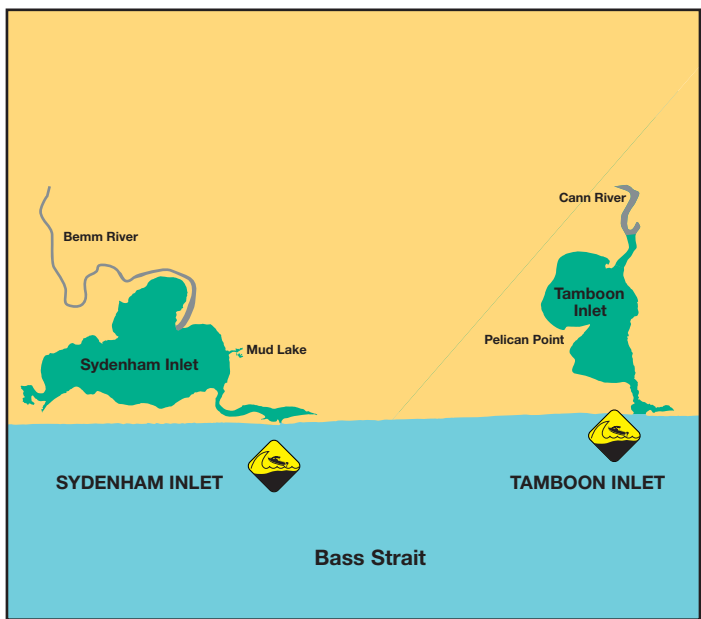

Coastal waters



Enclosed waters



Inland waters



- Strong tides, currents and dangerous waves may exist where enclosed waters meet coastal waters
- Enclosed waters sealed off from coastal waters may break out causing extremely dangerous conditions
- An anchor and flares must be carried when boating in enclosed waters
- Check conditions prior to departure.

Before you go boating



Properly maintain your vessel

- Inspect propeller nut and pin
- Check for water and fuel leaks
- Ensure bung is suitable and in good condition
- Ensure bilges are clean and dry
- Test steering for stiffness
- Check wiring
- Check and clean fuel filter
- Clean cooling system passages
- Replace outboard pull cord, if fraying.



Fully charge your batteries

- Top up battery cells with distilled water and check each cell with a hydrometer
- The battery should be charged, never overcharged
- The terminals, cables and casing should be kept clean
- Test all electrical equipment operating from the battery such as radios, gauges, power tilt, navigation lights, etc.



Ensure you have sufficient fuel

- Allow 1/3 out, 1/3 return and 1/3 reserve
- Always replace old fuel after periods of inactivity
- Inspect fuel lines, manual priming bulb and connections for cracks, leaks, etc.
- Inspect the fuel tank for cracks or corrosion.



Maintenance notes

	Pre-Season	Mid-Season	Post-Season
Fuel tank	<ul style="list-style-type: none"> • Avoid using old fuel • Keep clean and dry 	<ul style="list-style-type: none"> • Maintain proper fuel/oil • Check for water in fuel 	<ul style="list-style-type: none"> • Store in dry place (vented) • Metal, swish with 2 stroke oil
Fuel line	Check for cracking and loose fittings	Watch for leaks	Drain
Fuel filter	Check and replace as necessary	Check and clean	Check and clean
Fuel system (If you suspect an ethanol fuel blend has been used)	<ul style="list-style-type: none"> • Drain and clean out tank • Clean fuel lines • Change fuel filters • Have engine fuel system checked and serviced 	<ul style="list-style-type: none"> • Do not leave ethanol fuel standing in any tanks • Check fuel filters • Monitor engine operating temperature 	Drain all ethanol blended fuel from tanks, fuel lines and carburetors.
Batteries	<ul style="list-style-type: none"> • Check electrolyte, top up with distilled water • Recharge, check mountings, clean terminals 	<ul style="list-style-type: none"> • Check electrolyte, top up with distilled water • Recharge, check mountings, clean terminals 	<ul style="list-style-type: none"> • Check electrolyte, top up with distilled water • Recharge regularly
Engine			Store upright
Pull cord	Replace if fraying		
Wiring	Check for cracking, loose wire and corrosion		
Spark plugs	Clean and gap or replace	<ul style="list-style-type: none"> • Watch for fouling, moisture • Keep engine tuned • Clean and gap as necessary 	
Cylinders	Check for compression		
Moving parts	Lubricate all moving parts	Lubricate every 60 days	Lubricate before storing
Power unit	Drain and refill gear case oil	Repeat every 100 hours of operation or once a season	
Cooling system	Clean passages	<ul style="list-style-type: none"> • Check ports for weeds • Flush after use in salt water 	<ul style="list-style-type: none"> • Flush with water • Drain all water by pull starting with plugs disconnected
Propeller	Sand or file small nicks	Check regularly	Check for repairs
Outer surface	<ul style="list-style-type: none"> • Clean • Replace anodes as appropriate 	Keep clean	Keep clean, touch up with paint

Pre-start check list

Vessel

- Make sure your vessel is seaworthy and the vessel is capable of making the trip you have planned.
- Before operating any switches or engines, check for petrol and/or LPG odours.
- Check lights and electrics operation such as radios, gauges, power tilt, etc. are working
- Ropes and lines should be in good condition and ready for use.

Equipment

- Ensure you have the correct safety equipment for the area you intend to operate in.
- Make sure all safety equipment is easily accessible and in good working order.
- Carry a radio. A 27 MHz or VHF will keep you in touch with Marine services and will be of great assistance if you get into trouble. A pocket transistor will help you, as you can tune into the weather forecasts.
- Undertake a radio check to ensure that your radio works and check that your mobile phone is charged and stored in a dry location.
- Check the gauge on your fire extinguisher and make sure its stored in an accessible location. A fire blanket must be carried in enclosed cooking spaces.

Supplies

- Ensure you have food and water for the trip and sufficient supplies in case of an emergency for everyone on board.
- Check that your vessel is not overloaded; take into account luggage and heavy equipment.
- Stow all gear securely and with even trim in mind.
- Ensure you have a complete First Aid kit.

Clothing

- Check you have adequate clothing for a change in the weather, make sure you won't be overexposed to sunlight, wind and rain.
- Carry adequate wet weather gear for the trip you are planning.
- Clothing should be comfortable and not restrict your movements. Clothing can reduce your buoyancy so wear a PFD.
- Check your ability to swim or float in your clothes. Try it out in shallow water so that you are prepared in case of emergency.

Navigation

- Get information about the area you are operating in, i.e. how to get there, how long it will take, and how to get back.
- Check the sea conditions, tides, weather, river flow and bar conditions as appropriate.
- Find out about any local dangers and special rules or regulations for the area.
- Coastal navigation courses are highly recommended.

Crew

- Ensure the right safety equipment for all persons onboard including a correctly fitted PFD.
- Let everyone on board know what safety equipment is carried, where it is stored and how it works.

Taking off

- Insist that everyone aboard is within the boat itself, not on the side decking, and especially not on the bow or where they will obstruct your view.
- Move off slowly. The same goes for returning to jetty, mooring or ramp.
- Always check for trailing ropes that may be caught in your propeller.



Let someone know before you go

Always let someone know where you are going, your point of departure and when you plan to return. If your plans change, let them know. Also give them a description or photo of your vessel, vessel registration number and details of the number of passengers on board. This will assist emergency services, should the need arise.

Download your trip details form from the TSV website (www.transportsafety.vic.gov.au) or obtain a trip details fridge magnet from TSV.

I'VE GONE BOATING

HERE ARE MY TRIP DETAILS FOR: (DATE) 16 / 05 / 2011

I am departing at: 5.00

I am departing from: St Kilda Marina

My trip intentions are: Fishing at Middle Brighton

I will return no later than: 12.00

Number of people onboard (including me): Two

Weather expected: late changes, 20 degrees, 10-15 knots SE

Keep a whiteboard marker handy to enter fresh trip details and ALWAYS inform a relative or a friend of your boating plans by leaving them with this card. If you fail to do this they should: **CALL 000 IMMEDIATELY**

Safe Loading

Overloading is dangerous and seriously reduces the stability and seaworthiness of your vessel. Overloading your boat reduces freeboard, making your boat less able to resist waves and more likely to be swamped.

Unless specified by the manufacturer, the maximum number of people which can be carried in a recreational vessel is represented in the table below:

Vessels less than 6 m in length

Length of vessel	Maximum passengers
Less than 3 m	Two people
3 m to less than 3.5 m	Three people
3.5 m to less than 4.5 m	Four people
4.5 m to less than 5 m	Five people
5 m to less than 5.5 m	Six people
5.5 m to less than 6 m	Seven people

Note:

- a child up to and including one year of age does not count
- each child over one year and under 12 years equals half an adult
- on recreational vessels with individual cockpits (for example, decked canoes or kayaks), the number of persons carried on the vessel must not exceed the number of individual cockpits, irrespective of the age of the person.

WARNING

This is the maximum carrying capacity for good conditions. A reduction in the maximum number of persons must be made in adverse conditions or when on the open sea.

Capacity of a person is assessed at 75 kg per person with an additional allowance of 15 kg per person for personal gear.

A reduction in the number of persons must be made when equipment and supplies exceed total weight allocated.

Note: For vessels 6 m in length and more, refer to the manufacturer's recommendation for carrying capacity or contact Transport Safety Victoria on 1800 223 022.

Vessel stability

Overloading your boat seriously reduces stability making your boat more likely to capsize.

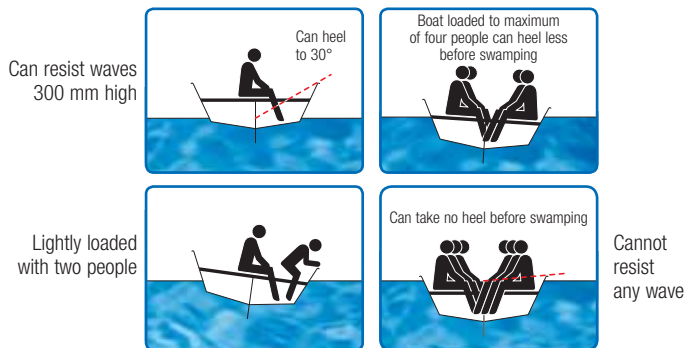

Minimum safety equipment

The tables on p. 18/19 show the minimum safety equipment that must be carried on board your vessel. This equipment is for your own safety and that of others on the water, and they are minimum requirements.

There are other things every sensible boat operator will also want to have aboard to enhance safety, confidence and enjoyment. Although not compulsory under the regulations, they are easily acquired and at reasonable cost. For example, a first-aid kit, drinking water and a basic tool-kit.

Seek advice on local conditions; it is advisable to carry the appropriate chart of the area you will be navigating. There are also excellent maps showing shallow areas by figures or colours and giving accurate details of launching ramps and anchorages.

Equipment exemptions

A person operating a vessel on State waters that is normally domiciled outside Victoria is exempt from the carriage of safety equipment requirements for a period of up to three months providing the vessel conforms with the carriage of safety equipment requirements of their home State or Territory. Interstate visitors must comply with the requirements to wear Personal Flotation Devices (PFDs) at specified times.

















The Director of Transport Safety may from time to time make a notice of exemption from equipment requirements for recreational vessels operated under certain circumstances. These exemptions are usually applied to incorporated clubs, organisations or associations that demonstrate a need for exemption and are only given where other appropriate safety measures are demonstrated. Refer to www.transportsafety.vic.gov.au for a current copy of the Notice of Exemptions.

Equipment placement and maintenance

















All safety equipment required to be carried on board must at all times be:

- placed or located in a conspicuous and readily accessible position
- kept in good order
- maintained or serviced in a way that ensures they are able to be operated in the way that they were designed to be operated
- serviced on or before the date specified by the manufacturer for that item of equipment.

Minimum safety equipment requirements for mechanically powered vessels

	Powerboat				Personal watercraft			
	COASTAL OFFSHORE (>2 nm from coast)	COASTAL INSHORE (<2 nm from coast)	ENCLOSED (Bays and estuaries)	INLAND (Rivers, lakes and dams)	COASTAL OFFSHORE (>2 nm from coast)	COASTAL INSHORE (<2 nm from coast)	ENCLOSED (Bays and estuaries)	INLAND (Rivers, lakes and dams)
 PFD (per person on board/towed)	Type 1	Type 1	Type 1	Type 1, 2 or 3	Type 1, 2 or 3	Type 1, 2 or 3	Type 1, 2 or 3	Type 1, 2 or 3
 Approved fire extinguisher (where any fuel is carried. Refer to relevant table to determine number and capacity required)	✓	✓	✓	✓				
 Waterproof buoyant torch	1	1	1	1	1	1	1	1
 Anchor and chain or line or both	1	1	1					
 Bailer (if no electric or manual bilge pumping system)	1	1	1	1				
 Bucket with lanyard (can also double as a bailer)	1	1	1	1				
 Electric or manual bilge pumping system (if vessel has covered bilge or closed underfloor compartments)	1	1	1	1				
 Pair of oars with rowlocks or pair of paddles (if vessel is up to and including 4.8 m)	1	1	1	1				
 Hand held orange smoke signals	2	2	2					
 Hand held red distress flares	2	2	2					
 Lifebuoy (if vessel is more than 8 m but less than 12 m in length)	1	1	1	1				
 Lifebuoy (if vessel is more than 12 m in length)	2	2	2	2				
 One dinghy or liferaft (if vessel is more than 12 m in length)	1	1						
 Compass	1							
 Marine radio	1							
 Red star parachute distress rocket	1							
 Approved EPIRB	1				1			

Minimum safety equipment requirements for sail and human powered vessels

	Off-the-beach sailing yacht				Yacht				Kayak, canoe, raft and rowing boat			
	COASTAL OFFSHORE (>2 nm from coast)	COASTAL INSHORE (<2 nm from coast)	ENCLOSED (Bays and estuaries)	INLAND (Rivers, lakes and dams)	COASTAL OFFSHORE (>2 nm from coast)	COASTAL INSHORE (<2 nm from coast)	ENCLOSED (Bays and estuaries)	INLAND (Rivers, lakes and dams)	COASTAL OFFSHORE (>2 nm from coast)	COASTAL INSHORE (<2 nm from coast)	ENCLOSED (Bays and estuaries)	INLAND (Rivers, lakes and dams)
 PFDF (per person on board/towed)	Type 1	Type 1 or 2	Type 1 or 2	Type 1 or 2	Type 1	Type 1	Type 1 or 2	Type 1 or 2	Type 1, 2 or 3	Type 1, 2 or 3	Type 1, 2 or 3	Type 1, 2 or 3
 Approved fire extinguisher (where any fuel is carried. Refer to relevant table to determine number and capacity required)					✓	✓	✓	✓				
 Waterproof buoyant torch					1	1	1	1	1			
 Anchor and chain or line or both					1	1	1					
 Bailer (if no electric or manual bilge pumping system)	1*	1*	1*	1*	1	1	1	1	1	1	1	1
 Bucket with lanyard (can also double as a bailer)					1	1	1	1				
 Electric or manual bilge pumping system (if vessel has covered bilge or closed underfloor compartments)	1	1	1	1	1	1	1	1	1	1	1	1
 Hand held orange smoke signals	2				2	2	2		2			
 Hand held red distress flares	2				2	2	2		2			
 Lifebuoy (if vessel is more than 8 m but less than 12 m in length)					1	1	1	1				
 Lifebuoy (if vessel is more than 12 m in length)					2	2	2	2				
 One dinghy or liferaft (if vessel is more than 12 m in length)					1	1						
 Compass	1				1				1			
 Marine radio	1				1							
 Red star parachute distress rocket	1				1							
 Spare oar with rowlock or spare paddle									1			
 Approved EPIRB	1				1				1			

* If vessel is not self-draining without intervention from the crew.

Personal Flotation Devices (PFDs)

Wearing of PFDs on recreational vessels

Victoria has requirements for the wearing of PFDs at certain times on recreational vessels. Under the regulations, you may be required to wear a specified type of PFD **when in an open area of a recreational vessel that is under way.**

When wearing of PFDs on recreational vessels is required at all times

All occupants of the following vessels are required to wear a specified PFD **when in an open area of a vessel that is underway:**

- Power driven vessels up to and including 4.8 metres (m) in length
- Off-the-beach sailing yachts
- Personal watercraft
- Canoes, kayaks and rowing boats
- Pedal boats and fun boats
- Kite boards and sail boards
- Recreational tenders.

Wearing of PFDs on recreational vessels during times of heightened risk

All occupants of the following vessels are required to wear a specified PFD (see table for PFD types) at times of heightened risk **when in an open area of a vessel that is underway:**

- Yachts (including monohull, trailerable and multihull yachts, excluding off-the-beach sailing yachts)
- Power driven vessels greater than 4.8 m and less than 12 m.

Heightened risk

- when the vessel is crossing or attempting to cross an ocean bar or designated hazardous area
- when the vessel is being operated by a person who is alone
- when being operated at night (commencing one hour after sunset and ending one hour before sunrise) or in periods of restricted visibility
- when there is significant likelihood that the vessel may capsize or be swamped by waves or the occupants of the vessel may fall overboard or be forced to enter the water
- when the vessel is operating in an area where: a gale warning, storm warning, severe thunderstorm warning or severe weather warning issued by the Bureau of Meteorology is current
- when the vessel is a yacht where there are no safety barriers, lifelines, rails, safety harnesses or jacklines in use.

What does under way mean?

Under way means not at anchor, made fast to the shore, or aground. If you are drifting you are under way.

Vessels travelling at any speed are at risk of being involved in an incident where the occupants suddenly and unexpectedly enter the water. Nationally, 17% of all fatalities occurred whilst the vessel was drifting, which is typically at slow speed.

What is meant by an open area?

An open area, in the case of a recreational vessel, means:

- all deck areas, including coach roofs, superstructures, open flying bridges, trampolines and nets, excluding areas within a rigid deck house, a rigid cabin, a rigid half cabin or a securely enclosed under deck space; or
- in the case of vessels without a deck, means the whole vessel excluding areas within a rigid cabin or a securely enclosed space; or
- in the case of kayaks or canoes, means the whole vessel.

Length of vessel – means length of hull (L_H). This includes all structural and integral parts of the craft, such as wooden, plastic or metal stem or sterns, bulwarks and hull/deck joints. This length excludes removable parts that can be detached in a non-destructive manner and without affecting the structural integrity of the craft, e.g. outboard motors, swimming platforms, bowsprits, fittings or attachments.

This measure is consistent with the International Standard, Small Craft – Principal Data Standard.

This is also the measure to be used when calculating vessel carrying capacity and when registering the vessel with VicRoads.

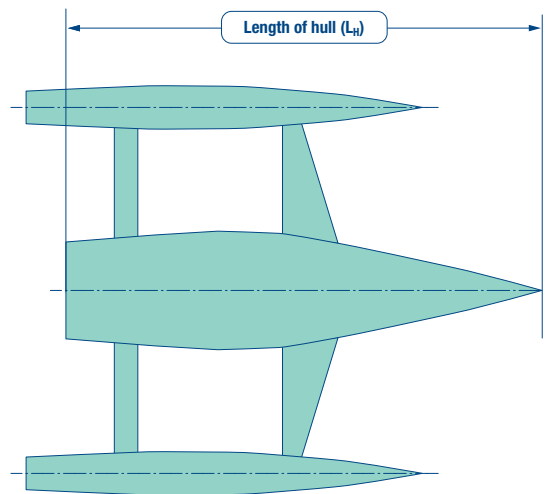
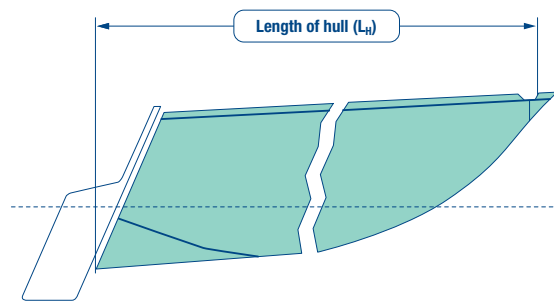
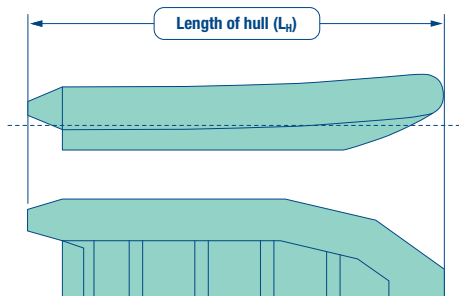
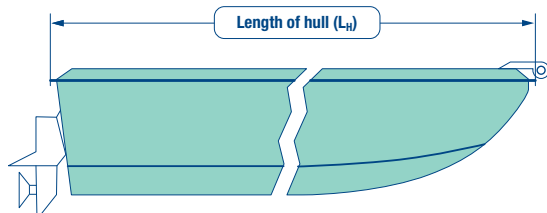

A PFD Type 1 is a recognised lifejacket. A PFD Type 1 will provide a high level of buoyancy and keep the wearer in a safe floating position. They are made in high visibility colours with retro-reflective patches.



Is your PFD legal?

A PFD Type 1 must comply with:

- Australian Maritime Safety Authority Marine Orders Part 25, Appendix 1, Section 4.1 SOLAS (Safety of Life at Sea) Life-jackets, or
- AS 1512—1996—Personal Flotation Devices—Type 1; or
- AS 4758.1 "Personal flotation devices Part 1: General requirements" relating to Level 275 PFDs; or
- AS 4758.1 "Personal flotation devices Part 1: General requirements" relating to Level 150 PFDs; or
- AS 4758.1 "Personal flotation devices Part 1: General requirements" relating to Level 100 PFDs; or
- International Standard ISO 12402-2:2006(E) "Personal flotation devices—Part 2: Lifejackets, performance level 275—Safety requirements"; or
- International Standard ISO 12402-3:2006(E) "Personal flotation devices—Part 3: Lifejackets, performance level 150—Safety requirements"; or
- International Standard ISO 12402-4:2006(E) "Personal flotation devices—Part 4: Lifejackets, performance level 100—Safety requirements"
- Uniform Shipping Laws Code, Section 10, Appendix R, or
- European Standard EN399 – 1993 Lifejackets – 275N, or
- European Standard EN396 – 1993 Lifejackets – 150N, or
- European Standard EN395 – 1993 Lifejackets – 100N, or
- Canadian General Standards CAN/CGSB-65.11-M88 (adults) CAN/CGSB-65.15-M88 (children), or

- Underwriters Laboratories Standards UL 1180, or
- New Zealand Standards NZ5823:2001 Type 401, or
- any standard or specifications approved by the Director of Transport Safety.

A PFD Type 2 is a buoyancy vest – not a lifejacket. It will provide less buoyancy than a PFD Type 1 but is sufficient to keep your head above water. Like a PFD Type 1 they are manufactured in high visibility colours.

A PFD Type 3 is a buoyancy garment – not a lifejacket. They have similar buoyancy to a PFD Type 2 and are manufactured in a wide variety of colours.



Is your PFD legal?

A PFD Type 2 must comply with:

- Australian Standard AS 1499-1996 – Personal Flotation Devices Type 2, or
- AS 4758.1 "Personal flotation devices Part 1: General requirements" relating to Level 50 PFDs; or
- European Standard EN 393:1994 "Lifejackets and personal buoyancy aids – Buoyancy aids – 50N", as formulated, issued, prescribed or published by the European Union from time to time; or
- International Standard ISO 12402-5:2006 "Personal flotation devices – Part 5: Buoyancy aids (level 50)— Safety requirements".
- European Standard EN 393 – 1993 Lifejackets – 50N.

A PFD Type 3 must comply with:

- Australian Standard AS 2260-1996 – Personal Flotation Devices Type 3, or
- AS 4758.1 "Personal flotation devices—Part 1: General requirements" relating to Level 50 Special Purpose PFDs.

What type of PFD must I wear?

When occupants of a vessel are required to wear a PFD, the following specified PFDs must be worn.

Vessel type	Coastal waters	Enclosed waters	Inland waters
Powerboat up to and including 4.8 m in length	PFD Type 1	PFD Type 1	PFD Type 1 or 2 or 3
Powerboat greater than 4.8 m and less than 12 m	PFD Type 1	PFD Type 1	PFD Type 1 or 2 or 3
Personal watercraft	PFD Type 1 or 2 or 3	PFD Type 1 or 2 or 3	PFD Type 1 or 2 or 3
Recreational tender	PFD Type 1	PFD Type 1 or 2	PFD Type 1 or 2 or 3
Off-the-beach sailing yacht	PFD Type 1(> 2 nm) or 2	PFD Type 1 or 2	PFD Type 1 or 2
Yacht	PFD Type 1	PFD Type 1 or 2	PFD Type 1 or 2 or 3
Kite board and sail board	PFD Type 1 or 2	PFD Type 1 or 2 or 3	PFD Type 1 or 2 or 3
Canoe, kayak, rowing boat, raft, pedal boat or fun boat	PFD Type 1 or 2 or 3	PFD Type 1 or 2 or 3	PFD Type 1 or 2 or 3

PFDs on children

Children under the age of 10 must wear a specified PFD at all times on any vessel when the vessel is under way and they are in an open area of the vessel.

When choosing a PFD for a child, care must be taken to ensure that the garment fits the child and that small children do not slip out when placed in the water.

Where possible a children's PFD that features a crotch strap is preferred, as it assists in holding the child in the jacket.



It is extremely difficult (and in some circumstances impossible) to put a lifejacket on if you are in the water, so prevent yourself and your crew from being in this situation and wear your lifejacket.



Persons being towed must wear an approved PFD Type 1, 2 or 3 at all times.

Fire

Most vessel fires start during fuelling procedures, or just after, when fumes are still present.

Fuel safety is the critical factor in the prevention of fire. Smell is often the best method of detecting fumes or spillage. Take sensible steps to minimise the risk.

Causes

- Defective equipment
- Carelessness
- Incorrect operation.

Prevention (on the vessel)

- Carry the appropriate approved firefighting appliances
- Do not stow fire extinguishers in the areas of potential fire risk for example, next to fuel caddies
- Check fire-extinguishers regularly
- Fit a smoke alarm (if you sleep onboard) and check it regularly
- Keep a fire blanket in the galley and stow it away from the stove
- Correctly install fuel and LPG by using a suitably qualified fitter
- Regularly check perishable fuel lines for wear and tear and carry a spare
- Fit a reminder notice above gas appliances – ('turn off gas when not in use')
- Fit detection devices for gas and fuel vapour and check regularly
- Keep the vessel neat and tidy and free of oil or fuel in the bilges
- Don't fit curtains above the stove
- After refuelling, ventilate bilges by opening hatches and operating a blower fan if fitted.

Prevention (at the marina)

- Know where firefighting equipment is located within the marina and how to use it
- Don't leave shore-supply electrical cables wound on a reel or drum, as the cables may overheat
- When refuelling, use a wide-mouthed funnel and clean up any splashes (fuel spills will make the deck dangerously slippery)
- If possible, fill the fuel tanks away from the vessel in a well ventilated, no smoking area
- Remember – do not refuel with persons onboard
- Secure spare fuel in a tightly capped, secure container
- Don't keep oily or fuel-soaked rags onboard
- Ensure moorings can be undone rapidly if a fire should occur.

Fire protection

Portable fire extinguishers are required on all recreational vessels (excluding PWCs) equipped with an electric start motor, gas installation or fuel stove or where any fuel is carried.

Fire extinguishers must be of a dry chemical type that complies with the relevant Australian Standard.

The following table describes the number of fire extinguishers that are required on a given vessel.

Figure 1

Vessel size	Number required
Less than 8 m	One of the nominated size
8 to 12 m	Two, one of which must be the nominated size
Greater than 12 m	Three, one of which must be the nominated size

The table below describes the minimum required size of one of the fire extinguishers on a given vessel.

Figure 2

Capacity of flammable or combustible liquids that are able to be carried on vessel	Minimum capacity of one of the required fire extinguishers
Less than 115 litres	0.9 kg
115 to 350 litres	2.0 kg
351 to 695 litres	4.5 kg
More than 695 litres	9.0 kg

Fire blankets

A fire blanket must also be carried on vessels where cooking facilities are located in an enclosed space, e.g. the galley on a yacht.

Bucket with lanyard

A bucket with lanyard must be carried on all powered recreational vessels (excluding PWCs). A bucket with lanyard allows water to be used to extinguish fires derived from wood, paper or plastics.

Fixed fire extinguishing systems

Vessels fitted with an approved fixed fire extinguishing system are exempt from the requirement to carry a nominated size extinguisher (see above Figure 2).

Example – 4.2 metre vessel

Michelle's 4.2 m aluminium boat with a 25 HP engine has a fuel carrying capacity of 40 litres.

The minimum fire fighting requirements are:

- One 0.9 kg dry chemical fire extinguisher (vessel less than 8 m, with less than 115 litre fuel capacity)
- One bucket with lanyard.

Example – 8.5 metre vessel

John's 8.5 m Sports Cruiser can carry 390 litres of fuel (including cooking gas) and has a galley below deck.

The minimum fire fighting requirements are:

- Two dry chemical extinguishers, one of which must be a 4.5 kg dry chemical fire extinguisher (vessel 8 to 12 m, with 351-695 litre fuel capacity)
- One fire blanket
- One bucket with lanyard.

Example – 13.5 metre vessel

Paul's 13.5 m Cabin Cruiser can carry 850 litres of fuel (including cooking gas) and has a galley below deck.

The vessel is fitted with a fixed fire extinguishing system of 22 kg capacity in the engine compartment.

The minimum fire fighting requirements are:

- An approved fixed fire fighting system of at least 9 kg capacity
- Two dry chemical fire extinguishers of any nominal size
- One fire blanket
- One bucket with lanyard.

Distress flares

Many recreational vessels are required to carry two hand-held red flares and two hand-held orange smoke flares, of an approved type when operating on coastal and enclosed waters.

- Distress flares have a life of three years – you must ensure the flares are replaced when their use-by-dates are reached.
- **Orange smoke flares**, which can be seen for up to 4 km (10 km by aircraft) should be used in daylight to pinpoint your position.

- **Red flares**, which have a visibility range of 10 km, are designed for use at night but can also be seen during the day.



1. Check instructions



2. Remove cap



3. Pull yellow knob upward and outward



4. Hold out and leeward

- A **red star parachute distress rocket** is designed to fire a single red star to a height of approximately 300 m. The star burns while falling for at least 40 seconds and can be seen from the greatest distance due to its intensity and elevation from sea level.
- Always delay using flares until you can see an aircraft, or until people on shore or in other boats are in visual range.
- Keep flares away from fuel and combustibles.
- Ensure flares are stored in an accessible but dry place, as they attract moisture.
- Be prepared – ensure everyone on board your vessel knows where the flares are stored and how to use them.
- Ensure that you carefully follow the activation instructions of all flares.



Red star parachute distress rockets are required by many vessels when venturing greater than 2 nm from the shore.

EPIRBs

All recreational vessels venturing more than 2 nm from the coast are required to carry an approved, current Emergency Position Indicating Radio Beacon (EPIRB). However, it is recommended that all vessels venturing into coastal waters carry an EPIRB.

Once activated, an EPIRB transmits a distress signal for at least 48 hours that can be detected by satellite and overflying aircraft. EPIRB alerts detected off Victoria are received at the Australian Maritime Safety Authority in Canberra and acted upon immediately. An EPIRB should be activated in situations where human life is in grave and imminent danger. The EPIRB should be accessible but stowed in a way to avoid accidental activation.

Check the battery and expiry date on your EPIRB before taking out your vessel. When testing an EPIRB, strictly follow the manufacturer's instructions.



Digital 406MHz beacons are required to be registered with the Australian Maritime Safety Authority. Analogue 121.5MHz beacons are no longer acceptable for use in the maritime environment.

Expired flares and EPIRBs

Approved flares and some EPIRBs have expiry dates clearly marked. Boat owners should dispose of their expired flares and EPIRBs at any of the following police stations:

Altona North	Frankston	Mornington	Rye
Apollo Bay	Geelong	Morwell	Sandringham
Bairnsdale	Hastings	Nunawading	Sorrento
Brighton	Heidelberg	Paynesville	Torquay
Broadmeadows	Inverloch	Port Campbell	Warrnambool
Cowes	Lakes Entrance	Portland	Werribee
Dandenong	Lorne	Prahran	Williamstown
Dromana	Mallacoota	Queenscliff	Wonthaggi
Foster	Mordialloc	Rosebud	Yarram

Compass

The requirements for a compass specify that it must be of an efficient type and maintained in accordance with section 230B of the Regulations. Therefore, an efficient compass may be deemed to include electronic compasses, wrist mounted compasses and any other type suitable for the purposes of efficiently establishing direction.



A compass is now required to be carried onboard when venturing further than 2 nm from shore.

Anchors

An anchor is an important item of equipment. Carrying requirements of equipment are highlighted in the minimum safety equipment table. When at anchor, attention is required to ensure the safety of the craft as changes in wind and sea conditions can affect the holding power.

The anchor, chain and line must be of sufficient length and durability for the area of operation. The line must be secured to the anchor and vessel at all times.

It is strongly recommended to use a length of chain between the anchor and line. The purpose of the chain is to keep the stock or shank of the anchor down as near as possible to parallel to the sea bottom. As a guide, the length of chain should approximately equal the length of the vessel.



Anchors are required to be carried on many vessels operating on coastal and enclosed waters. (See further information on anchoring on page 45.)

Marine radio

Marine radios provide a unique means of calling for assistance if a vessel is in distress, monitoring and/or updating rescue operations, and positioning a vessel by radio direction finding. Operators are also able to check weather conditions through one of the many marine Coast Stations and Limited Coast Stations.

Marine radios using 27 MHz, VHF or MF/HF frequencies are available for general use on board vessels. On recreational vessels, 27 MHz or VHF are the most common.



A marine radio is required on many vessels when venturing further than 2 nm from the coast.

The operator

Except for 27 MHz equipment, the relevant certificate to operate a MF/HF/VHF radio is the Marine Radio Operators Certificate of Proficiency. Further information and a copy of the Marine Radio Operators Handbook can be obtained from the Australian Maritime College on (03) 6335 4869.

Operating procedures

Use of standard procedures as described in the handbook avoids confusion and shortens transmitting time. Unnecessary chatter can mask a weak call for help and one day that may be your call. Only the recommended phonetic alphabet should be used in bad conditions.

Your two-way radio is your communication lifeline so it is important to remember that you:

- do not transmit unnecessarily
- listen before transmitting and avoid interfering with other stations
- commence your call on the calling distress channels, 27 MHz – 27.880 (Ch. 88), VHF Channel 16 or HF frequencies 4125, 6215 and 8291 kHz
- for distress messages, maintain best contact and be guided by the coast or limited coast station
- for non-distress messages, arrange to switch to a working channel once you have contacted whom you have called
- always use your call sign or the name of the vessel for identification – use of given names or surnames is not permitted
- keep messages brief and clear
- if making a distress call, it is important that you give your position, the nature of the distress, the time afloat, the type of vessel and the number of people involved
- stop transmitting when requested to do so by a coast station.

Distress/Urgency procedure

- A distress signal is used only where there is grave and imminent danger to a vessel or person
- An urgency message is used when help may be needed, but the danger is not grave and imminent.

Distress and urgency communications can be made on the following channels:

Radio type	Channel
VHF	16
27 MHz	27.88 MHz
HF	4125, 6215 and 8291 kHz

Alarm signal

An alarm signal is used to attract the attention of operators to the following message. It produces a two-toned warbling sound which can be easily distinguished, even in poor reception conditions.



Distress call

'MAYDAY MAYDAY MAYDAY, this is... (name of vessel and call sign)'. Spoken three times.

Distress message

A distress message has absolute priority over all other transmissions and may only be transmitted on the authority of the skipper or the person responsible for the safety of your vessel.

A distress message is:

- 'MAYDAY MAYDAY MAYDAY, this is – the name or other identification of your vessel (repeated three times)
- particulars of your position in the degrees and minutes of latitude and longitude or in relation to a well-known geographical feature
- the nature and kind of distress and the kind of assistance desired
- any other information to facilitate rescue including the number of people on board.

If no answer is received, repeat the distress call and message, particularly during 'silence' periods on the other distress frequencies or any other available frequency on which help might be obtained.

Urgency call

When the distress call is not fully justified, the urgency call 'PAN PAN' (spoken three times) should be used to indicate that a very urgent message follows concerning the safety of a vessel or person. The call details should be the same as for a distress message with the message beginning: 'PAN PAN, PAN PAN, PAN PAN'.

Safety signal

Safety signals are used when a station wants to pass important information concerning safety such as navigational warnings or weather warnings and are identified by the word: SECURITE (spoken three times as SAY-CURE-E-TAY).

27 MHz Marine Channels



VHF Marine Channels

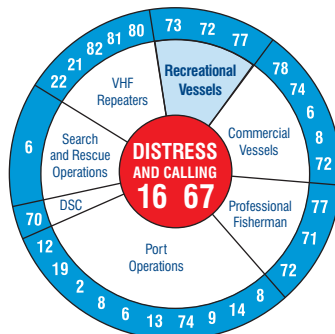

Local knowledge

In addition to complying with the appropriate Victorian boating legislation and requirements, it is important to find out if there are any special local rules when you are away from your home waters. Seek advice on local conditions and carry the appropriate chart of the area you will be navigating. There are excellent maps available showing shallow areas by figures or colours and giving accurate details of launching ramps and anchorages. Contact the local waterway Manager for more information.

Inland waters

Boaters operating on inland waters should take particular care as these waterways may change dramatically due to water level variation as a result of drought, seasonal variation and irrigation. Many waterways are currently experiencing significantly lower water levels resulting in an increased risk of collision with submerged hazards such as trees, shallow sand bars and other snags.

Boaters should take note of the following:

- Take account of the low water levels and submerged hazards – if in doubt, slow to 5 knots or less
- seek out local knowledge on conditions and hazards
- always maintain a good lookout
- ensure the motor kill switch is attached to the driver
- take note of signage at boat ramps
- ensure the vessels is equipped with the required safety equipment and that it is in good condition and easily accessible
- do not overload the vessel.

Lakes and water storage dams can become very rough in windy conditions. Always be on the lookout for changing weather conditions and obtain an up to date weather report prior to heading out.

Many inland waters can have very cold water temperatures even during warmer months of the year. Prepare for immersion by carrying and wearing warmer clothing when appropriate.

Interstate boating

If boating interstate you are required to adhere to the safety and operating rules imposed by that State. Victorian's visiting other States or Territories should contact the relevant local authority prior to travel to ensure compliance with safety equipment and other operating requirements.

The following waterways are recognised as Victorian waters for the purposes of transport safety legislation:

- the waters of Ovens River south of the Murray Valley Highway Bridge
- the waters of Lake Hume downstream of the Bethanga Bridge
- the waters contained within the Victorian border of the lower Glenelg River.

Those waters of the Murray River, Lake Mulwala and Lake Hume not listed above are within New South Wales jurisdiction. Operators are advised that NSW legislation applies on these waters.

The specific operating rules for each Victorian waterway are set out in the "Vessel Operating and Zoning Rules". An up to date copy of the rules can be accessed on TSV's website at www.transportsafety.vic.gov.au

Marine weather information

Internet

Visit www.bom.gov.au/marine for the latest weather charts, satellite and radar images as well as warnings, and forecasts out to four days. This site also provides links to tidal information, sunset and sunrise times as well as full schedules for all radio and phone services.

Radio

27 MHz	There are weather services provided on 27 MHz by some limited coast stations.
VHF	<ul style="list-style-type: none"> • Coast Radio Melbourne broadcasts weather forecasts for waters in and around Port Phillip and Western Port on VHF Channel 67 at: 0648 and 1848 EST (add one hour for EDST). An announcement will be made on Channel 16 before the broadcast. • Some Limited Coast Stations broadcast weather forecasts at various times.
MF/HF	<ul style="list-style-type: none"> • The bureau of meteorology broadcasts weather forecasts to Eastern Australia from Charleville on: All hours -- 8176 and 12365 kHz By day (7am-6pm) -- 4426 and 16546 kHz By night (6pm-7am) -- 2201, HF 6507 kHz • Scheduled broadcast times for Victorian coastal waters are: 0130, 0530, 0930, 1330, 1730 and 2130 EST (add one hour for EDST) • Warnings are broadcast every hour starting 0000 EST. • Some Limited Coast Stations broadcast weather forecasts at various times.

Telephone weather services

For the latest forecasts and warnings dial **1196** which automatically routes your call to the closest applicable service, based on the location of the phone from which you are calling.

Potential hazards and conditions

Weather

Check the weather forecasts, which are regularly updated and give warnings of strong winds and gales. Sudden squalls are not easy to predict in Victoria, so keep a sharp lookout and regularly check the horizon for telltale clouds or whitecap waves.

Head for the shore or the protected side of an island only if you are close. If possible, head into the wind and waves at a steady speed.

Squalls usually last only for a short period. It is often best to ride them out, keeping your bow into the wind and maintaining a speed sufficient to give you steering. Don't let the vessel drift side on to the wind and waves, your vessel may take on water or capsize.

Without power or anchor, drag a sea anchor from the bow to keep the boat pointing towards the waves. A sturdy bucket or oar on a rope may make an adequate sea anchor.



Occupants of specified vessels are required to wear PFDs when the vessel is operating in an area where a gale warning, storm warning, severe thunderstorm warning or severe weather warning issued by the Bureau of Meteorology is current.



If you do capsize, stay with your boat until help arrives. Your boat will be more visible than an individual in the water.

Wind

Wind blows roughly parallel to lines (isobars) on the weather map, clockwise around LOWS and anticlockwise around HIGHS. The closer together the isobars, the stronger the wind.

Hills, valleys and islands funnel winds, causing stronger and gustier winds and producing localised shifts in direction. This sometimes occurs over most of Port Phillip Bay when the wind is easterly. The Latrobe Valley funnels the air, producing quite strong winds over most of the bay, while lighter winds occur in the far northern portion. This effect often occurs on inland waterways that are surrounded by hills.

Know what the forecast is telling you

Wind can change direction and strength very quickly. It is important to understand the following terms when reading a weather report:

- **Wind speed** over the water is given in knots. When wind is mentioned in forecasts it refers to the average wind over a 10 minute period at a height of 10 metres
- **Gusts** are increases in wind speed lasting for just a few seconds. They typically range 30-40 per cent greater than the average wind speed
- **Squalls** are a sudden large increase in windspeed (usually accompanied by a change in wind direction) that lasts several minutes and then suddenly dies.

The Bureau of Meteorology issues a:

Strong Wind Warning	For winds averaging more than 25 knots and up to 33 knots
Gale Warning	For winds averaging 34 knots and up to 47 knots
Storm Warning	For winds averaging 48 knots or more

Transport Safety Victoria strongly advises operators of small craft not to go boating when any of the above weather warnings have been issued.

The Bureau of Meteorology's marine forecasts describe mean conditions over reasonably large areas such as 'Northern Bass Strait' or 'Port Phillip Bay'. Reference to squalls and thunderstorms alert vessel operators to adverse weather conditions expected for short periods of time within the forecast period. Forecasts may not reflect local conditions where topographic influences might channel or block wind and affect wave development. Vessel operators should be familiar with local variations in certain wind streams before venturing out – ask the locals for advice.



If stranded on the water, stay with your boat.

Waves

Waves, which are larger than the boat was designed to handle, are a major cause of accidents and drownings on both inland and coastal waters.

Wave heights mentioned in forecasts refer to 'significant wave height' – being the average of the highest one third of waves. Larger waves do occur, especially in regions where tides and currents oppose wind-driven wave direction.

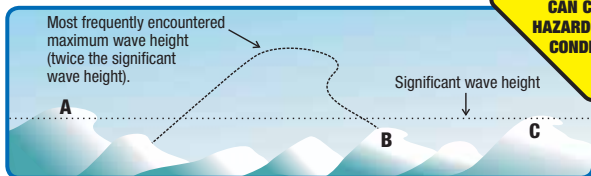

EXAMPLE OF WAVE HEIGHTS ON PORT PHILLIP BAY

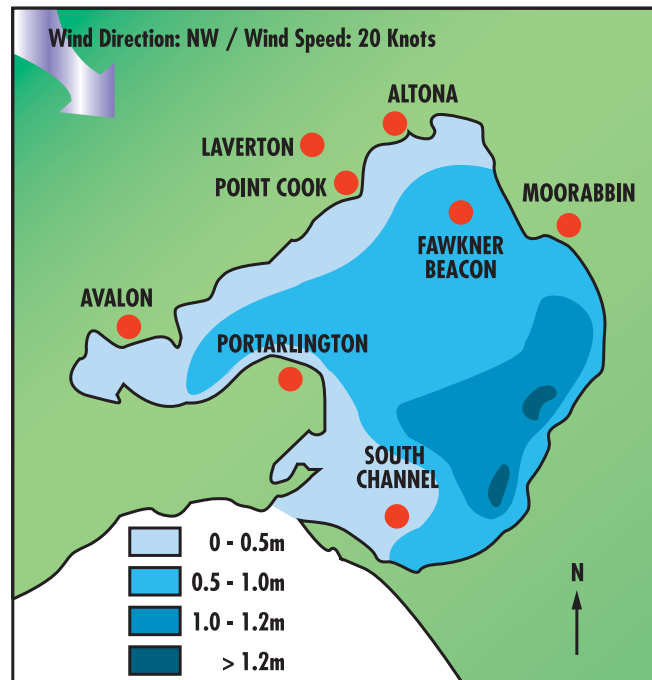

Thunderstorms

Thunderstorms are a serious hazard for boats. Cumulonimbus or thunderstorm clouds (see diagram) produce strong, gusty winds, which blow out from the front of the storm. If you see this type of cloud, you should watch which way it is moving – clouds often move in different directions from the wind at the surface. If it looks like it will pass over or within a few kilometres of you, head for shore immediately.

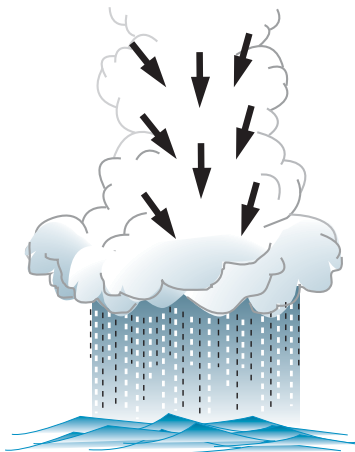

Safety hints

- Know the local factors that influence sea conditions and know where to reach shelter quickly
- Learn how to read the weather map
- Be aware that the weather map in the morning newspaper was drawn the day before
- Always check the latest forecast and warnings before going to sea and know what conditions exceed your safety limits
- Beware of rapidly darkening and lowering cloud – squalls may be imminent
- When at sea, listen to the weather reports on public or marine radio
- Be flexible – change your plans if necessary.

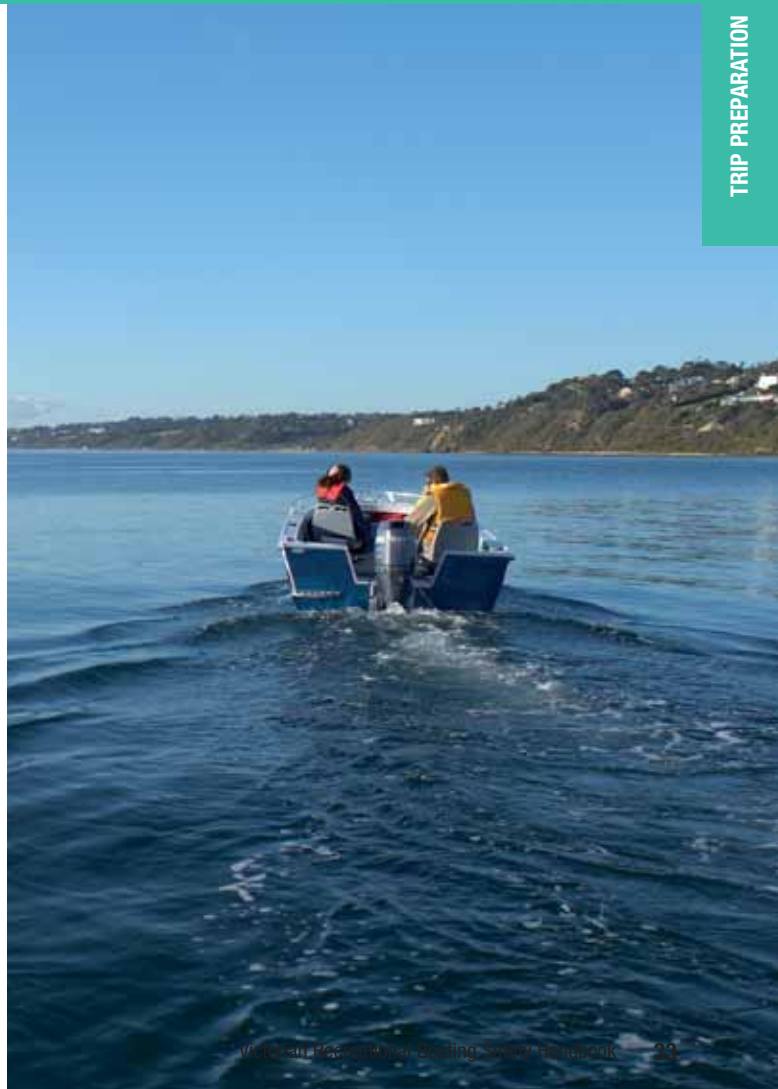

Crossing ocean bars

A bar is an accumulation of sand or silt at the entrance of a river, creek, lake or harbour. Even on a good day, they may produce sudden hazards for boat operators.

Exercise extreme caution

- Conditions on a bar change quickly and without warning
- No amount of experience or boat type makes crossing a bar safe.

Obtain local knowledge

Assess weather conditions and obtain tide information.

Be aware

- Night crossings are more hazardous
- Vessels attempting to cross a bar at, or near, low water are more likely to experience adverse conditions
- It is always preferable to cross on an incoming tide.



Preparing to cross a bar

- Ensure deck openings, hatches and doors are securely battened down
- Stow all loose gear and put on PFDs.

Crossing a bar

- Check where other vessels are crossing the bar – this will be the likely spot where you will want to cross
- Monitor the:
 - prevailing wind
 - wave pattern timing, i.e. looking for sets
 - course to follow
 - bar traffic
 - alternate routes.
- Motor slowly toward the breaking waves looking for the area where waves break last or not at all
- If there seems no break in the waves, slowly power through each oncoming wave
- Ensure that you are not going too fast over each wave as this would cause the vessel to ‘bottom out’ if it dives heavily
- If possible, make the crossing with the waves slightly on the bow so that the vessel gently rolls over the crest of each wave
- When approaching from sea, increase power of the vessel to catch up to the bigger set of waves and position the vessel on the back of a wave. Do not surf down the face of a wave.



If in doubt, don't go out.

Shipping operations

Transit only zones

A transit only zone is a regulated area of water in the vicinity of a commercial shipping channel or fairway. Small boat operators must not anchor, moor, drift or engage in fishing activities within a transit only zone.

The purpose of designating a transit only zone is to:

- avoid potential collisions between small boats and large commercial ships, and
- for the safety of small boat operators and their passengers.

A transit only zone in Port Phillip Bay extends from Point Gellibrand (Williamstown) south to an imaginary line at latitude 38° South. Yellow “special mark” light buoys are used to define the boundary zone (see map right).

Shipping traffic in other areas

Shipping channels and their approaches are high shipping hazard areas. Small boat operators should exercise caution and steer well clear in these areas.

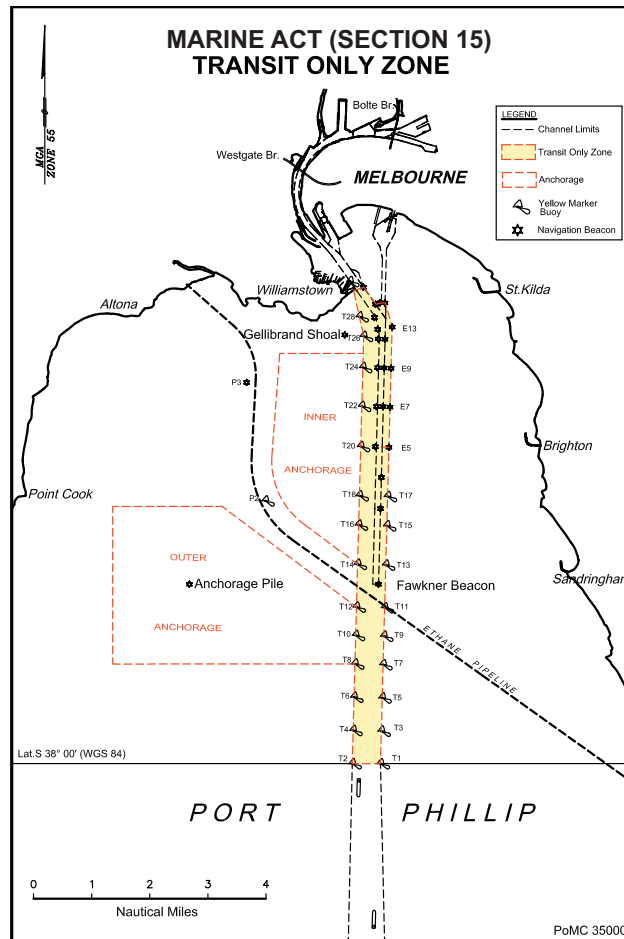
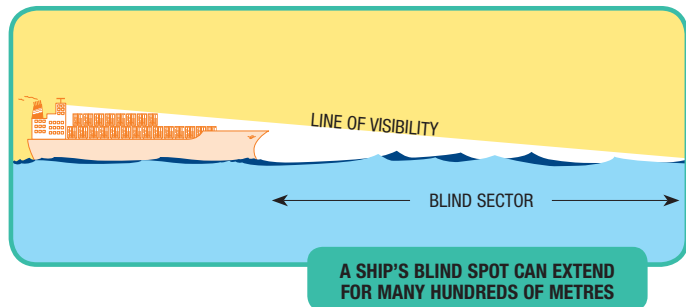

Environmental and wildlife regulations

Victoria's natural areas are suffering major problems due to the side-effects of recreational activities. Help protect the environment by observing the following commonsense rules:

- launch and retrieve your boat at designated boat ramps
- reduce your vessel speed to five knots near the edge of lakes and rivers
- dispose of all rubbish including fishing line, bait bags and food scraps appropriately
- use sewage disposal facilities and prevent pollutants such as petrol and oil from entering the water.

Further information is available from local offices of the Department of Sustainability and Environment (DSE) on 136 186.

Heritage areas

There are more than 700 historic shipwrecks in Victorian waters. Any ship that sank more than 75 years ago is protected by the *Heritage Act 1995 (State Waters)* or the *Commonwealth Shipwrecks Act 1976 (Commonwealth Waters)* and the regulations. Protected zones have been declared around eight shipwreck sites, seven of which are in Port Phillip Bay.

It is an offence to enter a protected zone. This includes fishing, trawling or any underwater activity such as diving within a protected zone. Penalties apply for these offences.

Remember: Protected Zone = No Entry (without a permit).

It is also an offence to damage, disturb or interfere with any historic shipwreck. This includes anchoring on it or removing objects from the wreck.

For further information on historic shipwrecks contact Heritage Victoria on (03) 8644 8800.

Whales, Dolphins and Seals

Rules are in place to ensure that whales, dolphins and seals are not disturbed by people in vessels.

Recreational boaters must not approach closer than 200m to whales or 100m to dolphins. Jet skis must not approach closer than 300m. When within 300m of whales, 150m of dolphins or 50m of seals you must:

- maintain a constant speed not exceeding 5 knots and avoid sudden changes in direction
- not approach a whale, dolphin or seal head on or be in their path
- leave the area if a whale, dolphin or seal shows signs of disturbance
- not separate any whale, dolphin or seal from its group
- not come between a mother and her calf/pup.

Some commercial operators hold permits to conduct tours that allow them within 100m of whales or 50m of dolphins.

Between 1 June and 31 October, vessels are prohibited from parts of Logan's Beach near Warrnambool, while Southern Right whales are in residence to rear their calves. There are protected seal colonies along the coastline where vessels are prohibited within 100m of a seal during breeding season (1 November - end February) and 50m of a seal outside of breeding season.

Report a whale or dolphin entanglement or stranding to the Whale and Dolphin Emergency Hotline (1300 136 017). For further information contact DSE on 136 186.

Recreational Fishing Regulations

Ensure you have a current copy of the *Victorian Recreational Fishing Guide*. This annual publication provides information such as size and bag limits as well as closed seasons. The guide is available free of charge from the Department of Primary Industries (DPI) Customer Service Centre on 136 186.

Report Illegal Fishing – call 13FISH

DPI welcomes reports of suspected illegal fishing activities anywhere in Victoria. Please call 13 FISH (133 474) anytime.

Aquaculture Fisheries Reserves

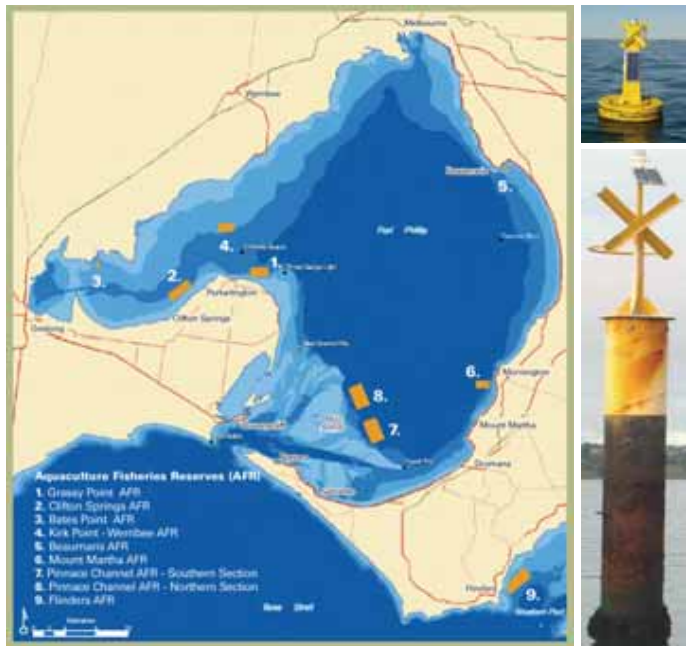

As part of the implementation of the Victorian Government response to the recommendations of the Environment Conservation Council for marine aquaculture, nine offshore marine Aquaculture Fisheries Reserves (Reserves) have been established in and around Port Phillip Bay.

DPI will be positioning navigation aids in these Reserves. These lit aids are Special Marks with the word 'Aquaculture' written on the yellow 'X' cross bar (see picture left). Recreational users of surrounding waters should proceed with caution if entering the Reserves.

For further information visit www.dpi.vic.gov.au/fishing or contact the DPI Customer Service Centre on 136 186.

Marine national parks and marine sanctuaries

The Victorian Government has created a system of 13 marine national parks and 11 smaller marine sanctuaries to ensure that representative samples of Victoria's marine environment are conserved for future generations.

Restrictions



No fishing, netting, spearing, taking or killing of marine life are permitted including all methods of fishing, from the shore or at sea.



Taking or damaging of animals, plants and objects (artefacts) is also not permitted. There are strong penalties under the National Parks Act for fishing in marine national parks and marine sanctuaries.

Boundary markers

Yellow On-shore Triangles

These are located at the park boundaries and point in towards the marine national park or marine sanctuary. In some cases there are two Yellow On-shore Triangles located one above the other. These two triangles can be used to get a lead to the boundary by aligning the two triangles, one directly above the other.



Yellow On-Shore
Triangles

Yellow In-water 'Special Mark'

These markers are found on buoys and piles and are used in waters to mark the boundaries of zones and other special areas.



In-water
'Special Mark'

Publications and further information

Parks Victoria is responsible for the day-to-day management of Victoria's marine national parks and marine sanctuaries. If you would like further information about Victoria's marine national parks and marine sanctuaries, please contact the Parks Victoria Information Centre on 131 963 or visit www.parkweb.vic.gov.au. On-site signage at key access points to individual parks and sanctuaries (for example, boat ramps) is also provided.

Environment protection

Some boating activities can have a significant impact on water quality. The discharge of wastes from boats may add nutrients and pollutants to our waterways and can pose a risk to ecosystems and to human health. The discharge of oil, chemicals, sewage, garbage, litter or any other waste is prohibited in any waters in Victoria.

To report a waste or pollution incident contact EPA on (03) 9695 2777 (metro areas) or 1800 444 004 or www.epa.vic.gov.au.

Marine Pests

Victoria's marine life is under threat from introduced marine pests. Port Phillip Bay is heavily infested with pests like the northern Pacific seastar and Japanese kelp.

Introduced marine species hitchhike from international or interstate waters on vessels big and small. They can be carried by ships, fishing boats, dinghies, cruisers, yachts, canoes, kayaks or even on fishing gear.

If your boat has been in infested waters, there could be marine pests that are either:

- Attached to the hull
- Tangled in the anchor, propeller, trailer, rods, nets, life jackets
- In damp places like the bilge, coiled wet ropes, pipes or buckets.

To stop pests spreading keep your boat and gear clean and dry.

Colour coded berthing zones

white or unpainted	<p>Temporary berthing zone</p> <ul style="list-style-type: none"> • Maximum time limit is 48 hours as per Port Services (Local Ports) Regulations • Vessels can be un-manned
	<p>Loading zone</p> <ul style="list-style-type: none"> • Loading zone for the pick up and drop off of passengers and cargo only • Vessels must be manned at all times
	<p>Short term zone</p> <ul style="list-style-type: none"> • Time limit as indicated • Vessels can be un-manned
	<p>Permit only zone</p> <ul style="list-style-type: none"> • Berthing prohibited without a permit • Vessels can be un-manned

Chapter 1 sample test questions

- 1 Q** The minimum number of approved PFD's that must be carried in a power vessel is?
- A** One for each person on board over 12 years, including persons over 12 years being towed.
- B** One for each person on board, including persons being towed.
- C** None, provided sufficient numbers of PFD-2s (buoyancy vest) and PFD-3s (buoyancy garment) are carried for each person on board and persons being towed.
- 2 Q** Under what age must all children wear a PFD in an open area of a recreational vessel that is underway?
- A** Six years.
- B** 10 years.
- C** 13 years.
- 3 Q** When must a waterskier being towed by a powerboat wear an approved PFD?
- A** At all times.
- B** Only if other water skiers are in the vicinity.
- C** Only at night.
- 4 Q** What is the minimum number of hand-held flares of an approved type that must be carried in a powerboat when operating on Victorian coastal waters within 2 nm from the coast?
- A** One red flare and one orange smoke flare.
- B** Two red flares or two orange smoke flares.
- C** Two red flares and two orange smoke flares.
- 5 Q** Is it compulsory for every powerboat operating on Victorian coastal and inland waters to carry a waterproof torch that is in working order?
- A** Yes.
- B** No.
- C** Only if the vessel will be used at night.
- 6 Q** Complete the following sentence. All powerboats carrying fuel (including cooking appliances) must carry an approved fire-extinguisher...
- A** Only on inland waters.
- B** Only on coastal waters.
- C** At all times.

- 7 Q** When about to undertake recreational boating, on what occasions is it advisable to inform relatives/friends or local authorities of your travel plans and estimated time of arrival at destination or return?
- A** Whenever bad weather is forecast.
- B** If travelling overnight.
- C** On every occasion.
- 8 Q** Which of the following wind warnings indicates that the average wind speed is expected to be 25 to 33 knots (45 to 60 kph)?
- A** Strong wind warning.
- B** Gale warning.
- C** Storm warning.
- 9 Q** What is the maximum number of persons over 12 years of age, a vessel 4.5 m to less than 5 m can legally carry.
- A** Four.
- B** Five.
- C** Eight.
- 10 Q** Where should safety equipment, such as fire-extinguishers, flares and PFDs be stowed in a vessel?
- A** Placed or located in a conspicuous and readily accessible position at all times.
- B** In compartments or lockers which are rarely used.
- C** As far away as possible from passengers who might accidentally damage them.
- 11 Q** When taking passengers on a recreational boating trip, should you brief them on the location and use of key safety equipment, such as fire-extinguishers, flares and lifejackets, before you start the journey?
- A** No, because you can operate the equipment if an emergency occurs.
- B** No, because you can always brief them later if an emergency occurs.
- C** Yes, it is highly advisable to brief passengers before the start of the journey.
- 12 Q** How often is it advisable to check your vessel's equipment and fittings, such as fuel and oil levels, fresh water, safety equipment, etc.?
- A** Before every journey longer than two hours duration.
- B** Before every journey, regardless of duration.
- C** Before every journey out of sight of land.
- 13 Q** Where could you find information on any local dangers and any special rules or regulations for a boating area with which you are unfamiliar?
- A** Charts, either local or official.
- B** Signs at boat ramps.
- C** All of the above.

- 14 Q A person under the age of 12:**
- A** is prohibited to operate any powerboat.
 - B** is permitted to operate a powerboat up to 10 knots.
 - C** is permitted to operate any powerboat provided they are under the supervision of a licensed person who is at least 16 years of age.
- 15 Q Holders of a restricted boat operator licence may:**
- A** tow a person.
 - B** operate at speeds of less than 10 knots when travelling alone.
 - C** operate at speeds in excess of 20 knots.
- 16 Q At what minimum age can a person be licensed to operate a powered vessel at any safe speed without supervision?**
- A** 12 years.
 - B** 16 years.
 - C** 18 years.
- 17 Q What is the permitted blood alcohol level for a person under 21 years who is operating a powerboat?**
- A** 0.00 – no alcohol permitted.
 - B** Less than 0.03.
 - C** Less than 0.05 – the same as for driving a car.
- 18 Q Dangerous sea conditions are often experienced over bars where lakes or streams meet the sea. During which of the following do the most dangerous wave conditions usually occur?**
- A** When northerly winds prevail.
 - B** When southerly winds prevail.
 - C** At slack water.

Answers

**Q1. B Q2. B Q3. A Q4. C Q5. A Q6. C Q7. C Q8. A
Q9. B Q10. A Q11. C Q12. B Q13. C Q14. A Q15. B
Q16. B Q17. A Q18. B**

CHAPTER 2. SAFE OPERATION

Boat handling

Steering and sailing rules

Sailing vessels approaching one another

When each has the wind on a different side, the vessel which has the wind on the port side shall keep out of the way of the other.

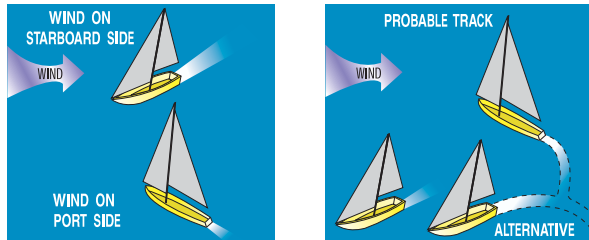

When each has the wind on the same side, the vessel which is to windward shall keep out of the way of the vessel which is leeward.

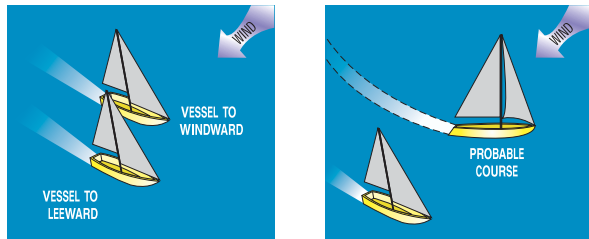

When a sailing vessel with the wind on its port side sees another sailing vessel to windward and cannot determine with certainty whether that sailing vessel has the wind on its port or its starboard, it shall keep out of the way of that other sailing vessel.

Power and sail vessels

Power-driven vessels shall keep out of the way of sailing vessels and rowing boats.

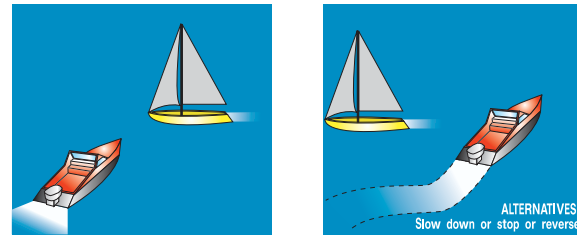

Power-driven vessels meeting head-on

Power-driven vessels meeting head-on or nearly head-on shall alter course to starboard so that each may pass on the port side of each other.

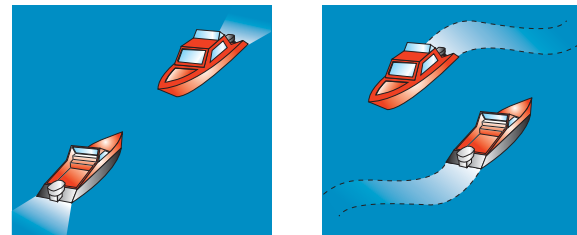

Power-driven vessels crossing

When two power-driven vessels are crossing, the vessel with the other on its starboard side shall keep out of the way and avoid crossing ahead of the other vessel. The other vessel must maintain its course and speed until it is apparent that the vessel required to give way is not taking appropriate action.

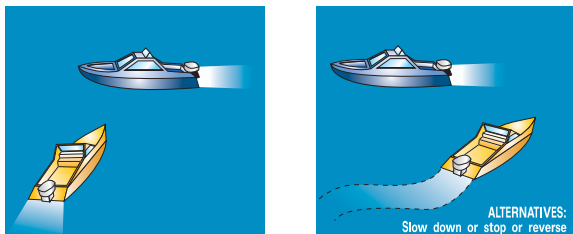

In narrow channels or channel approaches

All vessels in narrow channels shall keep as far as practicable, to the starboard side of the channel.

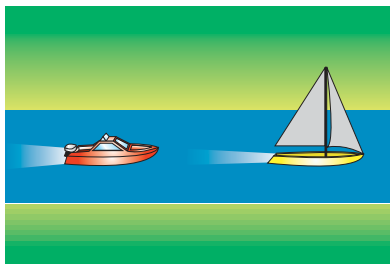

- (a) A vessel engaged in fishing shall not impede the passage of any other vessel navigating within a narrow channel or fairway

- (b) A vessel shall not cross a narrow channel or fairway if such crossing impedes the passage of a vessel that can safely navigate only within such channel or fairway
- (c) Any vessel shall, if the circumstances of the case permit, avoid anchoring in a narrow channel
- (d) A sailing vessel and a vessel under 20 m in length shall not impede the passage of any vessel which can safely navigate only within a narrow channel or fairway.

Overtaking vessels

All vessels, whether sail or power, overtaking another vessel when the boats are in sight of one another shall keep out of the way of the vessel being overtaken. That is, if a vessel is coming up with another from any direction, which is more than 22.5 degrees (in the shaded arc of the diagram below) abaft her beam, it shall be deemed to be the overtaking vessel until finally past and clear.

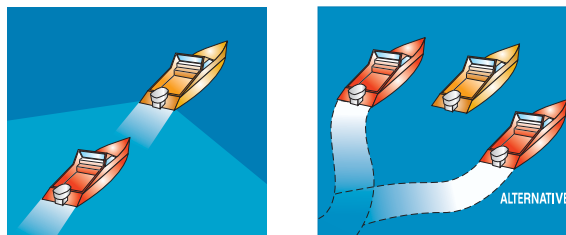

General notes

- If in doubt, assume that you are the overtaking vessel and keep clear. Alteration of course by either vessel does not relieve the overtaking vessel of the responsibility of keeping clear
- If overtaking or approaching a vessel engaged in waterskiing always keep at least 50 m from the skier and vessel combination.

Joint emergency action

The giving-way vessel shall take early and positive avoiding action; make course/speed alterations obvious to the other vessel; avoid crossing ahead of the vessel with right of way; if necessary stop or reverse.

A series of five or more short and rapid blasts on a whistle or horn should be used to indicate that insufficient action is being taken to avoid collision.

The vessel with the right of way shall keep its course and speed. It should take avoiding action only if that taken by the giving-way vessel is insufficient. If necessary it should take whatever action is available to keep clear and avoid a collision.

If a power-driven vessel is taking action to avoid a collision with another power-driven vessel, it shall, if possible, avoid altering course to port. This action does not relieve the vessel operator of handling obligations.

Steering and sailing rules – restricted visibility

In restricted visibility, reduce to minimum speed. When hearing the fog signal of another vessel ahead, proceed with caution until danger of collision is over or stop until you have ascertained the danger.

Fishing vessels

All vessels not engaged in professional fishing shall keep out of the way of vessels fishing with nets, lines or trawls or other gear that restricts manoeuvrability.

By day, a vessel engaged in fishing is required to display two black cones (apexes together) where it can best be seen – this does not apply to recreational anglers.

By night, a professional fishing vessel is required to display either of two light combinations:

- a red light over a white light, or
- a green light over a white light.

Responsibilities between vessels

A vessel under power gives way to:

- A vessel not under command
- A vessel unable to manoeuvre easily (including large vessels navigating in or near a channel or fairway)
- A vessel engaged in fishing (with apparatus such as trawling gear restricting its ability to manoeuvre)
- A sailing vessel (but see below).

A sailing vessel must keep clear of:

- A vessel not under command
- A vessel unable to manoeuvre easily (including large vessels navigating in or near a channel or fairway)
- A vessel engaged in fishing (with apparatus such as trawling gear restricting its ability to manoeuvre).

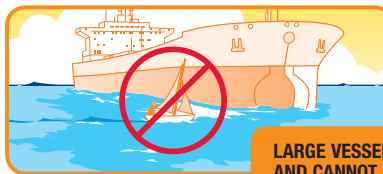

LARGE VESSELS CANNOT ALTER COURSE QUICKLY AND CANNOT STOP QUICKLY

Large vessels

Recreational vessels have a responsibility to stay well clear of large vessels. Small craft are prohibited from impeding the passage of big ships. All boat operators should take note of the following:

- Big ships operate at all times of the day and night
- The speed of a ship can be deceptive and may travel at speeds in excess of 20 knots
- Ships can weigh up to 100,000 tonnes and do not have brakes. They cannot stop or change course suddenly and will travel a long distance before stopping
- A ship's blind spot can extend for many hundreds of metres ahead
- Bow waves caused by a ship can swamp a small boat hundreds of metres away
- Sailing vessels do not have right of way over big ships
- A ship may sound five short blasts on its whistle if it believes you are at risk of a collision. Small vessels must take evasive action immediately.



**DON'T BOAT, JET SKI OR WINDSURF
IN AND AROUND LARGE VESSELS**

Anchoring

Anchoring is not only a normal part of boating, it is also an important safety measure in an emergency. Anchoring may keep the vessel safely positioned head on to heavy conditions and it will also allow you to retain your position and not be swept away or on shore.

Anchoring tips

- Choose your anchor, chain and/or line carefully to suit your vessel requirements and the depth of water you are likely to operate in
- Always lower the anchor rather than hurling the anchor and chain overboard, this may lead to tangling
- As a rule of thumb, the line paid out should be at least three times the depth of water. This distance should be increased to five to one in rougher seas
- Regularly check the anchor is not dragging by inspecting the rope tension and monitoring your position
- Never anchor from the stern or midship, you may risk swamping the vessel
- It is illegal and dangerous to tie up vessels to navigational aids and to anchor in channels.



**IT IS ILLEGAL AND DANGEROUS TO TIE UP TO
NAVIGATIONAL AIDS AND TO ANCHOR IN CHANNELS**

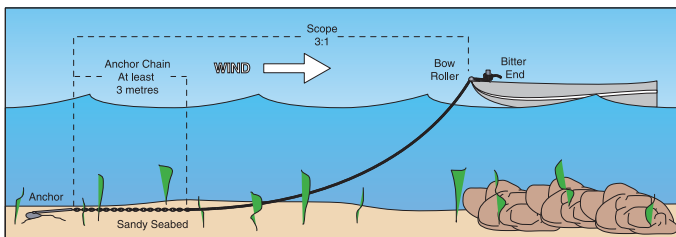

The use of a sliding buoy system in anchor recovery is not recommended. If the anchor is to foul, large forces may be transferred to the vessel leading to capsize or damage to the vessel.

Launching

Launching a boat from a trailer, and its retrieval (loading) are important skills. In each instance, the steps to be taken must be carefully planned and executed to ensure safety and to avoid damage to the vessel.

- Make pre-launch preparations well away from the ramp
- If you're launching a trailer sailer, check for overhead wires before you rig or move your boat
- Line up the car and trailer so that the backing process will be straight and as short as possible
- Study the ramp and surrounding water area for any hazards
- Do not remove the trailer winch or safety chain until your vessel is in the water
- Secure lines to the bow and stern, then either float or motor off with care.

Retrieving

- Align the centre of your vessel to that of the trailer; proceed carefully up the trailer until the winch or safety chain can be secured
- If you are not confident in driving your vessel on to the trailer, you can secure a line to both the bow and stern to control the boat as you use the winch
- Vacate the ramp as quickly as possible and park in the appropriate preparation area to finish securing the vessel for towing.

Remember, secure your vessel to the trailer using both the winch and safety chain.

Harbourmaster's directions

In port waters the relevant harbourmaster may make special directions concerning the navigation and operation of recreational vessels. For instance in port waters for Port of Geelong, Port of Melbourne and Port of Portland the following directions apply:

The master of a vessel less than 25m in length shall ensure that the vessel keeps out of the way of:

- vessels more than 25m in length
- a tug or launch assisting the movement, berthing or unberthing of another vessel
- the master of another vessel less than 25m in length shall ensure the vessel does not approach within 30m of a ship berthed at a tanker terminal.

A copy of the Harbourmaster's Directions for the Port of Melbourne, Geelong, Hastings, Portland and Gippsland Ports is included in the Port Operating Handbook which can be purchased from the relevant authority.

Navigation

Most collisions between vessels result from carelessness: everyone on the water has a legal, as well as moral, duty to maintain a proper lookout and travel at a safe speed at all times.

This duty includes the handling of a vessel and observing the rules, knowing the limitations of your vessel, being aware of potential hazards and allowing for the actions of others, both reasonable and unreasonable.

It pays to take care

An operator can be deemed to be negligent if proper care was not taken subject to circumstances. When someone handles his or her vessel in such a way as to cause an obvious and serious risk of physical injury to another using the same waters, or to property, that is reckless navigation.

The authorities and the courts regard both recklessness and negligence most seriously.

Dangerous navigation – propelling a vessel at speed or in a manner causing real or potential danger to any person or property – is also a punishable offence. So is any use of a vessel resulting in nuisance or causing obvious annoyance to any other person, deliberately or accidentally.

Getting there and back

Conditions can change quickly. It is not uncommon on Victorian waters for there to be sudden onsets of fog, dust and rough weather that can severely restrict visibility. This is where a compass, nautical chart, depth sounder and basic navigation aids come in handy. A GPS system can also be a valuable piece of equipment to have on board.

Operating at night

Navigating at night can be hazardous. It is more difficult to judge speeds and distances at night or in restricted visibility, than during the day. You must take every precaution. Vessels under way must show the proper lights from sunset to sunrise and in restricted visibility. You must also be able to tell from the lights of other vessels what they are, what they are doing and their direction of travel, so you can take the right timely action to avoid collision.



Occupants of vessels are required to wear PFDs when the vessel is under way and they are in an open area of the vessel.

You must familiarise yourself with navigation hazards, fixed or otherwise, lit and unlit, and whose position may occasionally change. Know where they are, from unlit buoys to rocks and shoals, and keep their position in relation to your vessel constantly in mind. Spotlights and torches may be used, but take care not to dazzle other people on the water, or yourself.

Always travel at a reduced speed to increase your safety margin. Keep a careful lookout around you for hazards and other vessels and, for extra reassurance, travel in company with another vessel or vessels where possible.

Only specified navigation lights can be shown at night. Any other lights onboard must not interfere with the range and arc of visibility of navigation lights.

A sharp lookout is important when the background of bright lights on shore tends to obscure the lights of other vessels, buoys and marks. This is especially true in waters close to populated areas, such as the shore of Port Phillip Bay where even larger ships can be hard to see.

Operating rules

The operation of a vessel can often be affected by physical conditions such as the direction of the wind, the depth of the water and visibility. When operating any type of vessel, always allow plenty of time and space in which to carry out any manoeuvre.



Operators of small vessels should appreciate the difficulties of large ships manoeuvring in congested or restricted sea areas or ports and, as a general rule, keep well clear of shipping.

The Steering and Safety Rules and the lights and shapes which must be displayed are set out in the International Regulations for Preventing Collisions at Sea (1972).

A good lookout must be kept by sight and hearing. The operator must be fully aware of the boating environment, especially in bad weather, restricted visibility or darkness. Don't forget to look all around you – even behind you. The operator is responsible at all times for keeping a proper lookout.

The specific operating rules for each Victorian waterway are set out in the “Vessel Operating and Zoning Rules”. An up to date copy of the rules can be accessed on TSV’s website at www.transportsafety.vic.gov.au

Speed restrictions

Speeding, together with alcohol, is one of the principle causes of boating accidents on Victoria’s waterways. The Victorian Water Police are empowered to use speed measuring devices to detect speeding vessels.

Speeds are limited by law, for specific boating areas, to meet local operation and safety conditions and usage. All speeds are measured in knots for the purpose of the *Marine Act 1988* and the Marine Regulations 2009.

Generally speaking, five knots is considered to be a fast walking pace.



On all Victorian waters a 5 knot speed limit applies to boat operators and PWC operators within a distance of:

- (a) 50m of a swimmer or bather
- (b) 50m of another vessel except where both vessels are either:
 - (i) engaged in competition or bona fide training organised in accordance with the rules of a state or nationally recognised water sporting association
 - (ii) within an exclusive area prescribed in a Schedule to a Notice which is set aside for a specific activity under clause 13 in which the width of water prevents the keeping of distance
- (c) 100m of a vessel or buoy on which a ‘diver below’ signal corresponding to the International Code Flag ‘A’ is displayed – a white/blue flag.



On all Victorian coastal and enclosed waters, or bays, a 5 knot speed limit applies to boat operators and PWC operators under the following conditions:

- (a) within 200m of the water's edge unless specifically excluded by Notice or where designated for other purposes
- (b) within 50m of any wharf, jetty, slipway, diving platform or boat ramp
- (c) when passing through a recognised anchorage for small vessels.



On all Victorian inland waters a 5 knot speed limit applies to boat operators and PWC operators within:

- (a) 50m of the water's edge unless the local authority specifically excludes those waters by Notice or they are designated for other purposes
- (b) 50m of any fixed or floating structure in or on the water.

Knots	Miles per hour	Kilometres per hour
1	1.15	1.85
5	5.75	9.26
10	11.51	18.52
20	23.02	37.04
30	34.52	55.56

General safety/operating rules

- 'Access lanes' provide access to the shore by waterskiers at speeds greater than 5 knots when otherwise it might not be possible. Bathers are not permitted within an 'access lane'
- Bathers must remain more than 50m from a boat ramp when it is in use or about to be in use
- 'No wash zones' are where a vessel must proceed at a speed that creates minimal wash
- Areas may be set aside where specific activities are prohibited (for example, no waterskiing, no bathing)
- Areas may be set aside for exclusive use or for special purposes (for example, sailing vessels only)
- On inland waters, vessels are required to travel in an **anticlockwise direction** in relation to the approximate centre of the waterway, except in a speed restriction zone or where local rules provide for travel in a clockwise direction.

Details of speed restrictions and local operating and usage rules are generally displayed on signage on the shore or marked by buoys or beacons in the water.

All vessels must travel at a safe speed at all times. A safe speed cannot be expressed as a maximum or minimum number of knots because it varies with circumstances and conditions. The operator must always assess the safety of the vessel's speed. A safe speed is one at which the vessel can be stopped in time to avoid any danger which arises suddenly.

Further information can be obtained from the relevant waterway manager (municipal council, water authority, etc.) or visit www.transportsafety.vic.gov.au.

Alcohol and drugs

'Drink driving' laws are strictly enforced with the objective of safety for all.



- The prescribed blood alcohol concentration (BAC) limit of 0.00 mg/100 ml applies to anyone, under 21 years who is operating a vessel or accompanying* a restricted licence holder on any vessel that is under way on all Victorian waterways – coastal and inland, public and private
- The prescribed blood alcohol concentration (BAC) limit of less than 0.05 mg/100 ml applies to anyone, 21 years or over, who is operating a vessel or accompanying* a restricted licence holder on any vessel that is under way on all Victorian waterways – coastal and inland, public and private.

* An accompanying operator is someone:

- who is over 16 years of age and who is appropriately licensed for the vessel being operated, and
 - who is accompanying a restricted licence holder when operating as per section b) on p. 2 of this handbook.
- The Victoria Police are empowered to use breathalysers to help detect operators exceeding alcohol limits. Heavy penalties apply to offenders
 - Alcohol increases body-heat loss, reducing your survival time if you fall overboard. It also increases the pulse rate, leading to rapid exhaustion in survival situations
 - Prescribed medications and other drugs can also pose problems. Many preparations for seasickness, hay fever and other allergies can make you feel drowsy or easily confused.

Check with your doctor or chemist on the possible side effects of any drugs you are obliged to take before you go boating.

Buoyage system

Ports and coastal waters

The buoyage system used in Victorian ports and around the coast is known as the 'IALA System A' which is a combined Lateral and Cardinal system. Although called a buoyage system, marks may be buoys, piles or beacons. Markers may contain one or more of the characteristics as described in this handbook, e.g. a marker may be colour coded but without a topmark.

Direction of buoyage

It is necessary to know the direction of buoyage. On the Victorian coast, this runs from east to west and into ports from seaward.

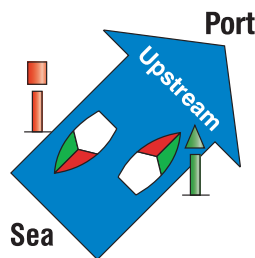

When leaving port the port-hand mark (red) should be passed on the vessels starboard (right) side.

Upon entering port the port-hand mark (red) should be passed on the vessels port (left) side.

As Western Port has two entrances, boundaries are laid down to indicate where the direction of buoyage from each entrance meets. They are

a line from just north of Lang Lang River to Palmer Point (French Island) to Observation Point (Phillip Island).

It is also necessary to know the direction of north and the other main points of the compass.

The operator of any vessel is prohibited from attaching a line to a navigational mark at any time.

IALA 'A' light rhythm types

Rhythm	Description	Navigation chart abbreviation
Flash	Duration of light shorter than duration of darkness	Fl
Occulting	Duration of light longer than duration of darkness	Oc
Isophase	Duration of light and darkness are equal	Iso
Quick Flash	A flash rate of 60 or 50 per minute	Q
Very Quick Flash	A flash rate of 120 or 100 per minute	VQ
Long Flash	A flash of not less than two seconds	LFI
Group Flash	A group of two or more flashes	FI(2) OR VQ(9)
Morse A	A light flashing Morse code signal 'A'	Mo (A)

Note:

- When the light exhibited is not white, the colour is indicated in the chart abbreviation by Y, R or G for yellow, red or green, for example, FI (4) Y;
- The period of a light (time between the start of successive sequences) is indicated in seconds by the letters, for example, FIR5s = single red flash every five seconds.

Buoyage types

There are five types of marks under the IALA System A: Lateral, Cardinal, Isolated Danger, Special and Safe Water.

Lateral marks

These are used to indicate the port (left) and the starboard (right) sides of the channels when travelling in the direction of buoyage, that is, into port.

Port-hand marks are coloured red and the basic shape is cylindrical (can) for buoy (and topmark when fitted). If lit, the light will be red and may have a rhythm. Such a mark would be on the port side of a vessel when travelling in the direction of buoyage.

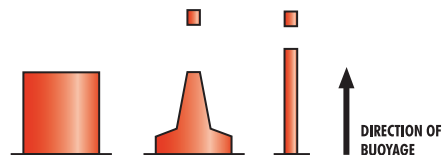

Colour: Red
 Shape (buoys): Cylindrical (can), pillar or spar
 Topmark (if any): Single red cylinder (can)

Lights: red when fitted may have any rhythm other than composite group-flashing (2+1) used on modified lateral marks indicating a preferred channel. Examples are:



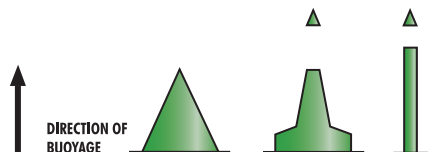

Q.R	Continuous quick light	
FI.R	Single-flashing light	
L FI.R	Long-flashing light	
FI (2) R	Group-flashing light	

Starboard-hand marks are coloured green (exceptionally, black may be used) and the basic shape is conical (and topmark when fitted). If lit, the light will be green on any rhythm. This mark would be on the starboard side of a vessel when travelling in the Direction of Buoyage.



Colour: Green
 Shape (buoys): Conical (cone), pillar or spar
 Topmark (if any): Single green cone point upwards

Lights: green when fitted, may have any rhythm other than composite group-flashing (2+1) used on modified lateral marks indicating a preferred channel. Examples are:

Q.G	Continuous quick light	
Fl.G	Single-flashing light	
L Fl.G	Long-flashing light	
Fl (2) G	Group-flashing light	

When marks are numbered, odd numbers will lie on the starboard side, and even numbers on the port when travelling in the direction of buoyage. They are numbered from seaward.

Cardinal marks

These are used to indicate the location of the best navigable water; to show the safe side on which to pass danger (rocks, wrecks, shoals, etc.) and to draw attention to a feature in a channel.

To understand the meaning of a particular cardinal mark, the navigator must be aware of his geographical directions and, therefore, needs a compass to indicate where the best navigable water lies. The mark is placed in one of the four quadrants: north, south, east or west. If in doubt, consult the chart.

The shape of a cardinal mark is not significant, but in the case of a buoy it will be a pillar or spar. The most important daylight feature of the Cardinal mark is the black double cone topmark and the four different arrangements that indicate the relevant direction from the mark.

Black and yellow horizontal bands are used to colour the Cardinal marks. If lit, the mark will exhibit a white light of Quick Flash (= about 1 per second) or Very Quick Flash (= about 2 per second) characteristic. The rhythm of the light will indicate the particular quadrant of the mark.

North cardinal mark

Has two cones pointing up. If lit, a north marker exhibits a continuous quick or very quickflashing white light.

Pass on the northern side of this mark.



East cardinal mark

Has two cones pointing away from each other. When lit an east mark exhibits a white light flashing in groups of three (3) quick or very quick flashes.

Pass on the eastern side of this mark.

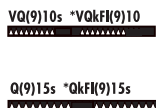
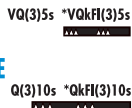

West cardinal mark

Has two cones point to point. When lit a west mark exhibits a white light flashing in groups of nine (9) quick or very quick flashes.

Pass on the western side of this mark.

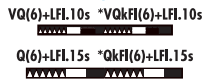

South cardinal mark

Has two cones pointing down. When lit a south mark exhibits a white light flashing in groups of six (6) quick or very quick flashes followed by a long flash.

Pass on the southern side of this mark.

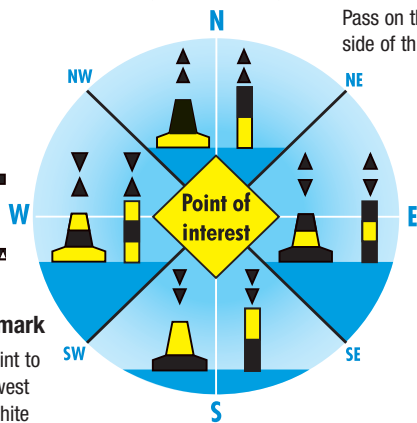

Special marks

These are used to indicate a special area or feature, the nature of which may be found by consulting a chart or sailing directions. Some local examples are the Spoil Ground, Pipeline and Recreation buoys in Port Phillip and the Pilot buoy off Flinders in Western Port.

The colour of the Special mark is always yellow, and the top mark is a single yellow X. If a light is fitted it will be yellow and may have any rhythm not used for white lights, for example, FIY, FI (4) Y.

In Victorian waters, Special marks are commonly used to indicate no boating zones.

Topmark (if fitted)



Shape: optional



Isolated danger marks

These are on, or moored above, an isolated danger of limited extent that has navigable water all around it. The colours are red and black horizontal stripes and the mark is, when practicable, fitted with a double sphere, vertically disposed, black topmark. If lit, the light will be white showing a group of two flashes. The association of two flashes equals two spheres and may assist the memory with this one.

Some examples of the Isolated Danger Mark are on the Prince George Bank off Indented Head, Wooley's Reef at Frankston and Eagle Rock in the Northern Western Port. Isolated Danger Marks are not always positioned centrally over a danger and it is therefore advisable not to pass too close.

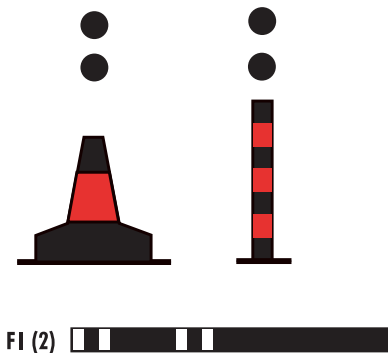

Safe water marks

These are used to indicate that there is navigable water all around the mark. These marks can be used as a centre line, mid-channel or landfall buoy. The Western Port Fairway buoy is a local example of this mark. The shape of the buoy is spherical, pillar or spar and is coloured with red and white vertical strips. The topmark, which is fitted when practicable to pillar and spar buoys, is spherical and red. If lit, an isophase occulting or single long flashing white light is exhibited. The buoy shape is optional but should not conflict with that used for a Lateral or Special mark.

Operators of vessels are cautioned that large commercial vessels may pass close by these marks.

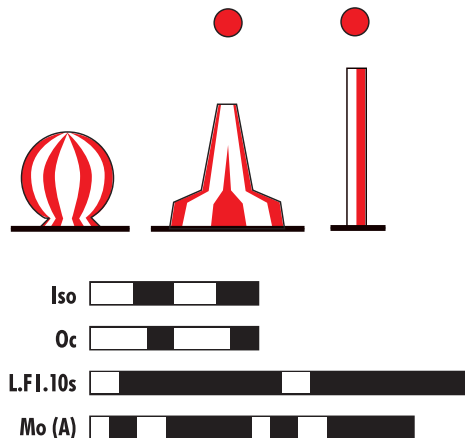

Zone signage

Inland Waters

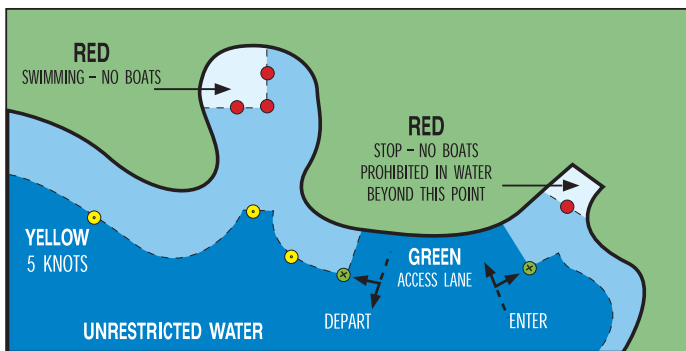

The marker buoy system of defining zoned water areas is now in common use on Victoria's Inland waters.

Red

'Stop – no boats' or
'Swimming – no boats':
used to mark prohibited
water and swimming areas.

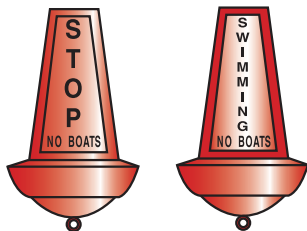

Yellow

Speed restrictions: an area is set aside as a speed restriction zone because excessive speed is a risk to the operator, to other vessels or persons, or to the environment. The yellow buoys may be placed because of local or general requirements for slower speeds.



Green

Access lane: the waters between these buoys are unrestricted to allow the picking up or dropping off of a waterskier.



Red and yellow

Special purpose: these unmarked buoys are used to signify regatta areas, hazards, channels, etc.

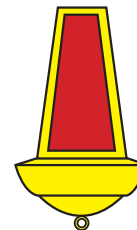

Mini-buoys

Small mini-buoys of the same colour may be used in conjunction with the larger buoys to demarcate an area.

Note: other buoy shapes may be used.

Coastal and Inland Waters

Sometimes signs on the shore are used instead of, or in addition to, buoys in the water, for example, 'no boating' zones or special purpose zones.

'Access lanes' are solely for waterskiing and marked by beacons on the shore with each boundary being delineated by the alignment of an orange disc and a black and yellow triangle beacon.

'Special Purpose' areas such as waterskiing only, PWC or kite boarding areas may also use onshore beacons to delineate the zone. In this case an orange disc may be used with a black and white triangle.

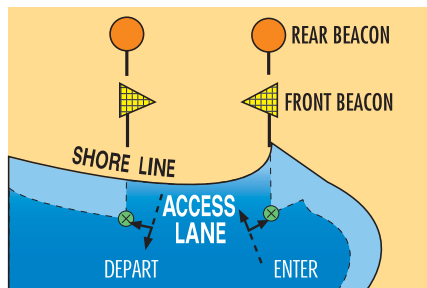

On-shore beacons

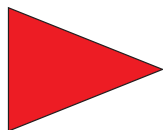

No Boating

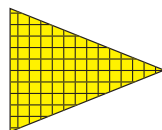

Access Lanes

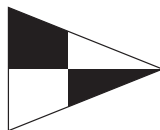

Special Purpose
(water skiing, PWC,
kite surfing, etc.)

Navigation lights

- Lights must be displayed from sunset to sunrise and in times of restricted visibility during daylight hours
- Minimum ranges at which lights can be seen refer to conditions on a dark night with a clear atmosphere
- Under way – a vessel is under way when it is not at anchor, tied to a jetty or shore, or aground.

Minimum visibility for length of vessel

(in nautical miles)

Light	Under 12 m	12 m up to 50 m	50 m and over
Masthead lights	2	5*	6
Sidelight	1	2	3
Sternlight	2	2	3
Towing light	2	2	3
All-round lights (white, red, yellow, green)	2	2	3

* Where the length of a vessel is 12 m or more, but less than 20 m, the masthead light visibility is 3 nautical miles.

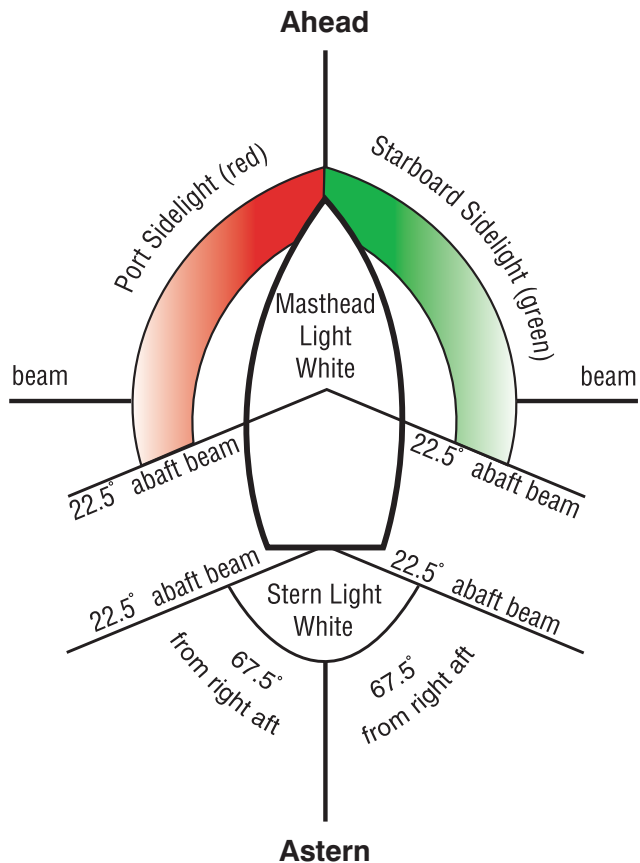

Sailboats and rowing boats

Sailing vessels under way

A sailing vessel under way shall exhibit sidelights and sternlight OR if the vessel is less than 20 m in length, the sidelights and stern lights may be combined in one lantern (tricolour lantern) carried at or near the top of the mast where it can be seen.

In addition to the sidelights and stern light, a sailing vessel may exhibit at or near the top of the mast, where they can be best seen, two all-round lights in vertical line the upper being red and the lower being green. These lights must not be exhibited in conjunction with a combined lantern (tricolour lantern).

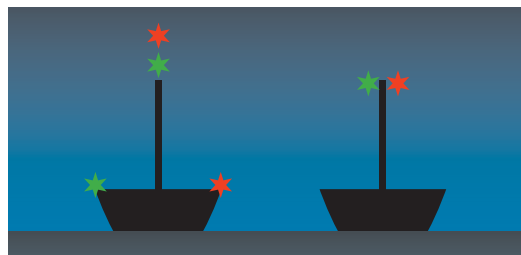
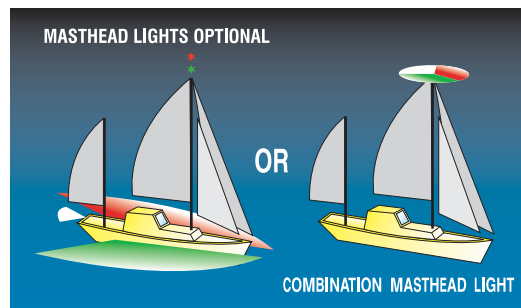

Reminder – a sailing vessel, whenever using its engine, with or without sails, is a power-driven vessel within the meaning of the rules, and must act accordingly and show the appropriate shapes by day and lights by night. This means that a tricolour lantern must not be used under power.

Sailing vessels under way (not using power) less than 7 m in length and boats under oars

If practicable, any of the combinations for vessels under sail or an electric torch or lighted lantern showing a white light and exhibited in sufficient time to prevent collision.

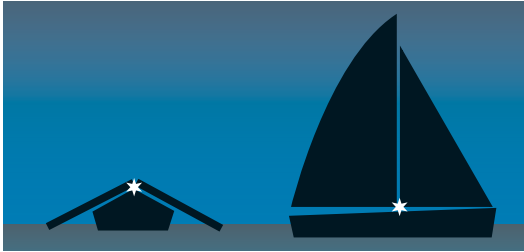

Vessels under 7 m in length not using an engine and unable to exhibit the lighting configuration

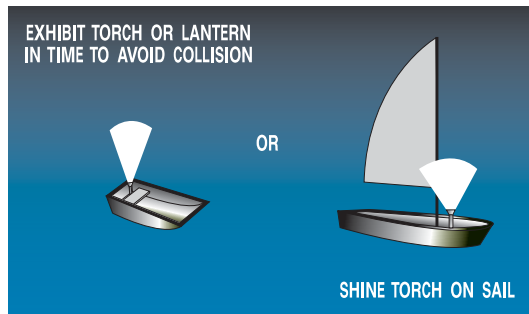

Powerboats

Powerboats under way

Vessels under 12 m in length must show the following lights

- a) sidelights, masthead lights and a stern light;
- or
- b) sidelights and an all round white light.

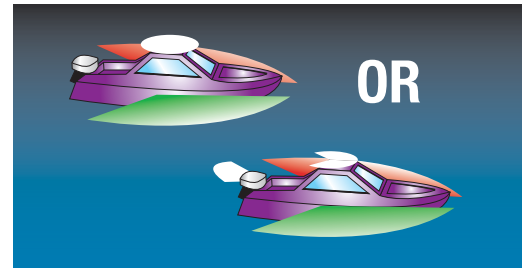

Vessels under 7 m in length and under 7 knots

Power-driven vessels of less than 7 m in length, whose maximum speed does not exceed 7 knots, when under way, may exhibit an all-round white light. Sidelights should also be shown if practicable.

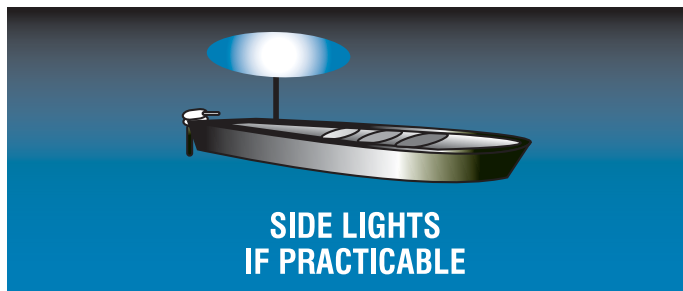

Recreational vessels at anchor

All recreational vessels **must** show an all-round white light while at anchor. If the vessel is drifting (under way but not making way) the vessel **must** display sidelights, masthead light and stern light.

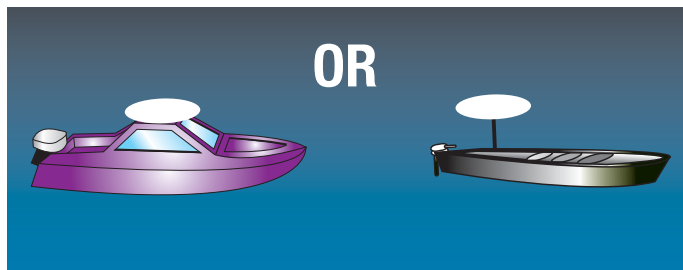

Larger vessels

Under 50 m in length

For vessels under 50 m in length, a second masthead light is optional.

For vessels under 12 m in length, sidelights may be a combined lantern – on fore and aft centreline.

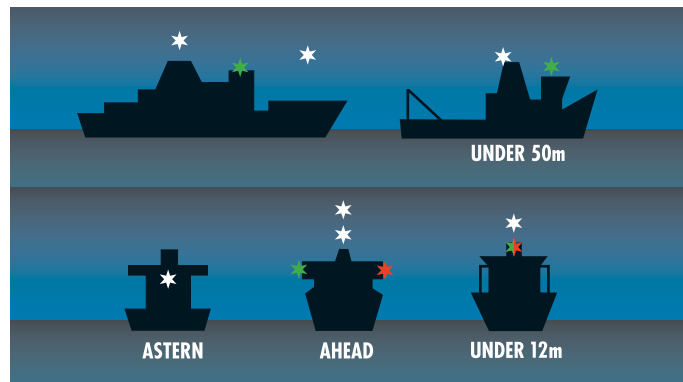

Vessel towing another vessel

When tow length is under 200 m, two masthead lights are shown (three masthead lights if over 200 m). A YELLOW towing light is situated over sternlight. Vessel towed shows side and sternlights.

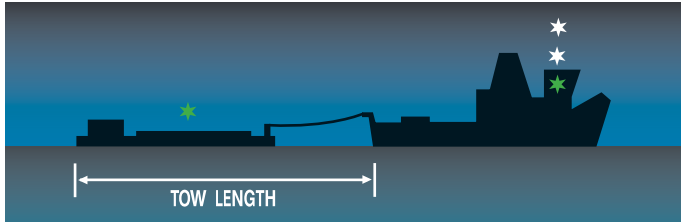

Vessel at anchor

Length 50 m or more: two all-round lights, the forward one higher than the aft one. Length under 50 m: second (lower) light at stern is optional.

A vessel of 100 m or more length shall also illuminate her decks with lights.



Vessel aground

Anchor lights and two all-round red lights.

Vessel under 12 m length is not required to exhibit these lights.

This signal does not mean distress or in need of help, but operators should navigate with caution.



Vessel restricted in ability to manoeuvre (includes diving vessels)

Three all-round lights, top and bottom lights red and the middle light white.

When making way through the water, vessel also shows masthead lights, sidelights and sternlight.

When at anchor, vessel also shows anchor lights.

This signal does not indicate distress or a need for help, but operators should navigate with caution.

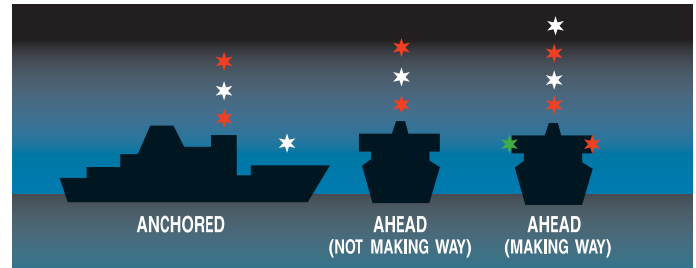

Vessel engaged in underwater operations or dredging

Vessel with an obstruction on one side shall, in addition to restricted ability to manoeuvre lights, carry two all-round red lights, on the side of the obstruction. Also two all-round green lights on the side that vessels may pass.

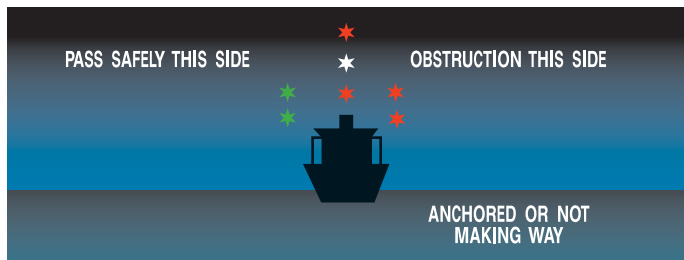

Vessel constrained by her draught

Power-driven vessel restricted to a narrow channel by her draught and thus unable to deviate from course.

Lights for power-driven vessel under way and three all-round red lights.

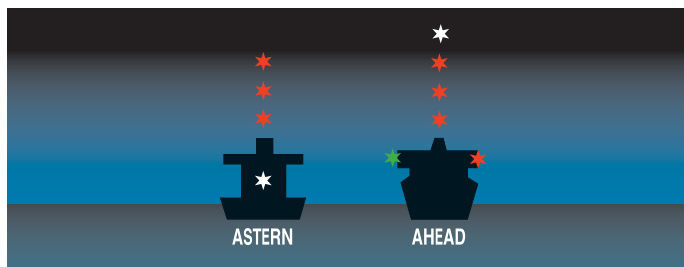

Pilot vessel on duty

Two all-round lights, the top light white and the lower light red.

When at anchor, shows anchor light or lights.

When under way, shows sidelights and sternlight.

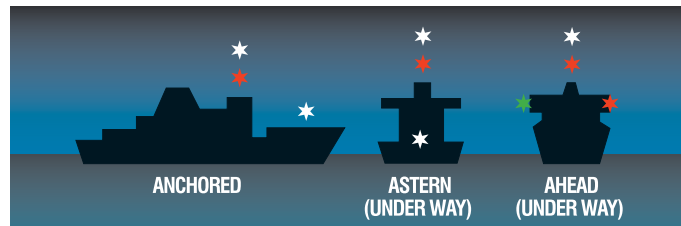

Vessel not under command

Two all-round red lights and when making way through the water, sidelights and sternlight (vessels under 12m in length are not required to comply with these lights).

This signal does not mean distress, but shows inability to manoeuvre. Vessels are required to keep clear of vessels not under command.

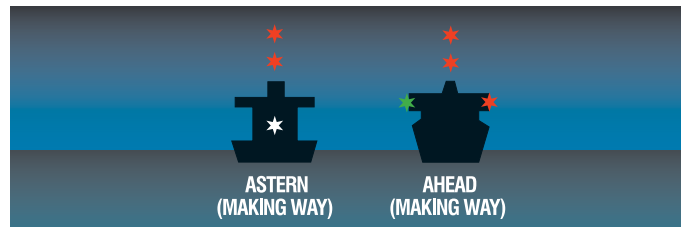

Commercial fishing vessel trawling

Two all-round lights, the top light green and the lower light white.

A rear masthead light is optional for fishing vessels under 50 m in length.

As making way through water, sidelights and sternlights are shown.

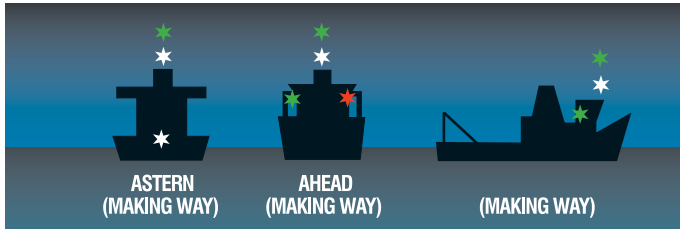

Fishing vessel (other than trawling)

Two all-round lights, the top light red and the lower light white.

If outlying gear extends over 150 m horizontally from fishing vessel, shows one all-round white light in direction of gear (sidelights and sternlight shown when making way through water).

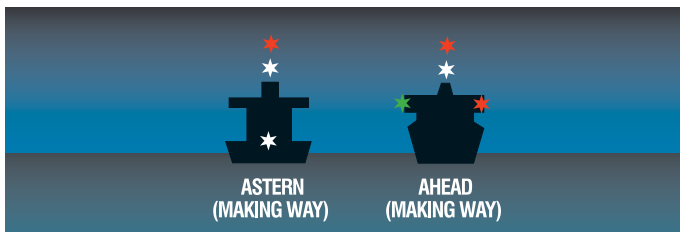

Vessel working in chains (for example, Raymond Island Ferry)

Vessel shows an all-round red light at each end and an all-round green light above the red light at the forward end to indicate the direction in which the vessel is proceeding.

Vessels operating in the vicinity of the Paynesville/Raymond Island vehicular ferry must proceed with caution and keep clear of the ferry.



Dayshapes for vessels

These signals are shown by day in all weathers on vessels to denote certain activities in which they are engaged.

In restricted visibility, the appropriate lights should also be displayed by day. You must be able to recognise these dayshapes which are generally used by larger vessels.

Vessel at anchor

Not required for vessels of less than 7 m when at anchor **not** in a channel or channel approach, or a usual anchorage, etc.

Forward, where best seen,
ONE BLACK BALL.



Vessel under power with sails set (motor sailing)

Forward, where best seen,
ONE BLACK CONE, point down.



Fishing vessel

Trawls, nets or other gear (under way or at anchor).

TWO BLACK CONES, points inwards.



Power-driven vessel towing

Vessel being towed if length of tow exceeds 200 m.

On each vessel where best seen,
ONE BLACK DIAMOND.

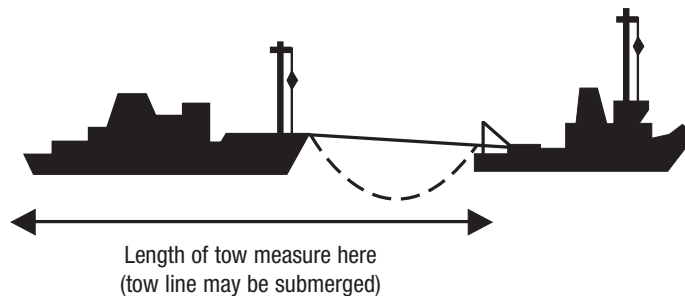

Vessel aground

This signal does not indicate distress or a need for help (not required for vessels under 12 m length).

Where best seen, THREE BLACK BALLS.



Vessel not under command

Not required for vessels under 12 m.

Not distress, but indicates inability to manoeuvre.

TWO BLACK BALLS.



Vessel constrained by her draught

Power-driven vessel restricted to a narrow channel by her draught and thus unable to deviate from her course.

Where best seen, ONE CYLINDER.



Vessel restricted in ability to manoeuvre

For example, vessels engaged in: flying aircraft, cable laying, replenishment at sea, underwater operations, servicing navigation marks, towing, where manoeuvre is restricted by tow.

This signal does not indicate distress or a need for help. When at anchor, vessel also shows anchor shape.

BLACK BALL, BLACK DIAMOND, BLACK BALL.



Vessel engaged in underwater operations or dredging

With an obstruction on one side shall, in addition to the above shapes, carry TWO BLACK BALLS on the side of the obstruction, and TWO BLACK DIAMONDS on the side on which vessels may pass.

BLACK BALLS ON BOTH SIDES may be used to indicate passage or channel is blocked and vessels should await instructions before proceeding.

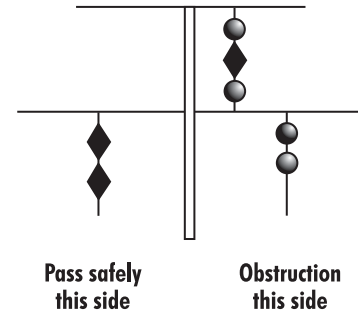

Diving operations from a small vessel

Any vessel with divers operating from it must always display signals by day or night to inform other vessel users.

The daytime signal for divers is an international Code Flag 'A', at least 750mm long and 600mm wide. It should be placed to ensure all-round visibility.



During night diving, a vessel must show the international signal for a 'vessel restricted in its ability to manoeuvre'. These are three lights in a vertical line, top and bottom are red and the middle one is white.

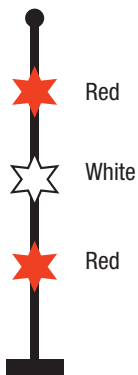





A five knot speed limit applies to vessel operators and waterskiers within a distance of 100 m of a vessel, buoy or structure on which a diver below signal is displayed.







Sound and light signals







Definitions and classifications

'Whistle' – means of making short or long blasts	
'Short blast' – about one second duration	
'Prolonged blast' – 4–6 seconds duration	
Vessels of 100 m in length or more – use whistle, bell and gong	
Vessels of 12 m in length or more – use whistle and bell	
Vessels of less than 12 m in length – use any efficient sound signal	

Manoeuvring and warning signals when vessels are in sight of one another. Whistle signals used below may be supplemented by light signals using the same code.

Description	Signal
'I am altering my course to starboard'	
'I am altering my course to port'	
'I am operating astern propulsion'	
Signal to alert another vessel that you are unsure of its intentions, or doubt whether you are taking enough action to avoid collision	

Warning signals – vessels in narrow channels. When the vessel being overtaken must take action to permit safe passing.







Description	Signal
'I intend to overtake on your starboard, please alter your course to permit me to pass'	
'I intend to overtake on your port, please alter your course to permit me to pass'	
Agreement by overtaken vessel	
A vessel in doubt about signals, intentions or safety of the proposed manoeuvre of an overtaking vessel	
Vessel nearing blind bend in channel	
Vessel other side of bend repeats	



Conduct of vessels in restricted visibility

Adapt vessel's speed to prevailing conditions and be prepared for instant course/speed alterations.

Every vessel, hearing another vessel's fog-signal apparently forward of the beam, should reduce speed to a minimum or stop. It should then use extreme caution until the danger of a collision is over.

Sound signals for vessels in restricted visibility (day and night)

Description	Max period	Signal
Power under way, and making way	every two minutes	
Power under way, and not making way through water	every two minutes	
<ul style="list-style-type: none"> • Not under command • Restricted manoeuvring • Constrained by her draught • Sailing ship – not under power • Vessel fishing • Vessel towing or pushing 	every two minutes	
Vessel towed – if manned	every two minutes	
Pilot vessel on duty – gives normal signals above and may sound four short blasts		
Vessel at anchor (under 100 m in length) BELL rung for five seconds	every minute	

Description	Max period	Signal
Vessel at anchor (100 m or more in length) BELL rung for five seconds from the bow of the vessel and then – GONG rung five seconds from the aft of the vessel immediately following bell signal	every minute	
Vessel at anchor – may give WARNING of possibility of collision to approaching vessel		
Vessel aground – as ‘anchor’ but preceded and followed by three separate and distinct BELL strokes		
Vessels under 12 m in length may make the appropriate signals given above but, if not, must make some other efficient sound signal every two minutes.		



Waterskiing including aquaplaning, paraflying, wakeboarding



Waterskiing is a popular and exciting recreational boating activity. Vessels engaged in waterskiing often travel at high speeds, so vessel operators should acquaint themselves with the local operating rules. The rules are generally displayed on noticeboards and are contained in the notices published in the *Victorian Government Gazette*.

Further information may be obtained from the relevant waterway manager (municipal council, water authority, etc.) or visit www.transportsafety.vic.gov.au.

Note that:

- any vessel towing a person/s must have an observer who is at least 12 years of age (NSW waters, including the Murray River, require an observer of at least 16 years of age)
- a maximum of three persons can be towed at any one time
- towing is only permitted in the period from one hour before sunrise and to one hour after sunset
- a person being towed is required to wear an approved PFD at all times
- once back in the vessel, the person being towed must wear the appropriate PFD for that vessel
- speed and distance restrictions apply to anyone being towed as well as to the vessel towing
- any vessel towing a person/s must have the carrying capacity for the operator, observer and the number of persons being towed.

Hand signals

1 – Speed Up

(Thumbs up)



5 – Cut Motor

(Slashing hand across throat)



2 – Slow Down

(Thumbs down)



6 – OK After All

(Hands clasped over the head)



3 – Turn

(Circling motion above head followed by pointing in the direction of the turn)



7 – Stop

(Hand raised with fingers outstretched)



4 – Back to Shore

(Pat top of head)



8 – All OK

(An 'O' made with the thumb and index finger)



Chapter 2 sample test questions

- 1 Q Who is responsible for keeping a proper lookout to avoid collisions?**
- A** The operator.
 - B** The passengers.
 - C** The owner.
- 2 Q Can you anchor inside a shipping channel to undertake recreational fishing?**
- A** Yes.
 - B** No.
 - C** Only during daylight hours when there is good visibility.
- 3 Q Can you tie your vessel to a navigation mark to undertake recreational fishing?**
- A** No.
 - B** Yes.
 - C** Yes, but only if the navigation mark remains visible to other vessels.
- 4 Q What is the speed limit for all vessels when operating within a distance of 50 m from a swimmer or bather on all Victorian waters?**
- A** Ten knots.
 - B** Five knots.
 - C** Any speed which you consider safe.
- 5 Q On Victorian coastal waters or ports, within what distance from the water's edge must you observe a speed limit of 5 knots unless otherwise zoned?**
- A** 200 m.
 - B** 100 m.
 - C** 50 m.
- 6 Q On Victorian inland waters, within what distance from the water's edge must you normally observe a speed limit of 5 knots?**
- A** No distance if no bathers or other vessels are present.
 - B** 20 m.
 - C** 50 m.

- 7 Q When should you switch on and display navigation lights on a vessel under way?**
- A** Only when it is dark.
- B** From sunset to sunrise and in restricted visibility.
- C** At night in port areas only.
- 8 Q Who can use an access lane?**
- A** Any vessel transferring passengers to or from the shore.
- B** Vessels conducting waterskiing.
- C** Any vessel wishing to anchor close inshore.
- 9 Q Other than special rules for narrow channels, traffic separation schemes and overtaking, power-driven vessels must keep clear of:**
- A** Sailing vessels under sail and not using power.
- B** Commercial fishing vessels conducting fishing operations and vessels with restricted manoeuvrability.
- C** All of the above.
- 10 Q Where should you operate a vessel in a narrow channel or river?**
- A** On the left-hand (port) side of the channel as far as practicable.
- B** In the middle of the channel.
- C** On the right-hand (starboard) side of the channel as far as practicable.
- 11 Q Access lanes, in which vessels towing waterskiers may approach or depart from the shore at skiing speed, on Victorian inland waters are marked by:**
- A** Two green buoys showing the words 'Access Lane'.
- B** Two sets of black and yellow triangle shore beacons, each aligned with orange disc beacons at the rear.
- C** Either one of the above or a combination of the two above.
- 12 Q What is the minimum age of an observer when a vessel is towing a waterskier?**
- A** 16 years.
- B** 12 years.
- C** 10 years.
- 13 Q An approaching vessel sounds five (5) short blasts on its horn. It is indicating that it is:**
- A** Altering its course to starboard (to its right).
- B** Operating its engines astern.
- C** Unsure of your intentions, or doubts that you are taking enough action to avoid a collision.

14 Q What does this mark indicate?
Safe navigable water lies to:

- A The north.
- B The east.
- C The south.

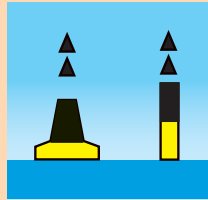

15 Q When travelling upstream (in from the sea) at night, on which side should you keep a flashing red light to stay within the channel?

- A Your left-hand (port) side.
- B Your right-hand (starboard) side.
- C Either side (it does not matter).

16 Q You want to anchor your vessel at night. Which of the following must be displayed?

- A An all round white light.
- B Sidelights and an all round white light.
- C No lights.

17 Q When travelling downstream (towards the sea), on which side should you keep this type of navigation mark to stay in the channel?

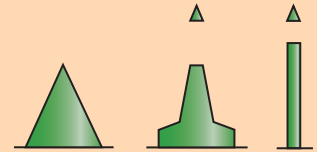

- A Your right-hand (starboard) side.
- B Your left-hand (port) side.
- C Either side (it does not matter).

18 Q In a situation where there is a risk of collision (as shown), the blue vessel should:

- A Keep its course and speed. It should take avoiding action only if the action taken by the giving-way vessel is insufficient.
- B Reduce its speed or stop until it is apparent that the giving-way vessel is taking avoiding action.
- C Alter its course.

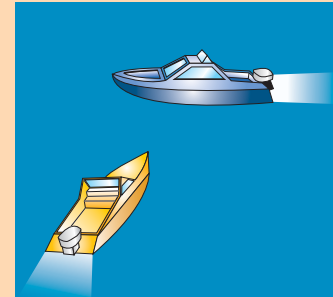

Answers

Q1. A Q2. B Q3. A Q4. B Q5. A Q6. C Q7. B Q8. B
Q9. C Q10. C Q11. C Q12. B Q13. C Q14. A Q15. A
Q16. A Q17. B Q18. A

CHAPTER 3. EMERGENCY PROCEDURES

ALL OCCUPANTS TO PUT ON PFDs



RAISE THE ALARM



- **MARINE RADIO**
27MHz – Ch 88
VHF – Ch 16



- **PHONE**
Call 000



- **FLARES**
Activate when you see
a potential rescuer



- **EPIRB**
Activate your
distress beacon

STAY WITH YOUR BOAT



- A vessel is a lot easier
to spot than a swimmer
- Anchor your boat
to maintain position
if safe to do so

Fire

Fighting the fire

- Raise the alarm (to others onboard and to rescue organisations)
- Manoeuvre the vessel to operate with the least wind effect (generally downwind)
- If within an enclosed or confined space, close all the hatches, vents and ports to reduce oxygen
- If a burning object can be safely moved, get it over the side quickly
- Shut off fuel lines and gas lines ASAP as flexible fuel lines may collapse and add to the fire
- Try to extinguish the fire with firefighting appliances and remember to direct the extinguisher into the heart of the fire not the flames
- Maintain a watch on the area once the fire has been extinguished to monitor any reflashes
- If you need to abandon the vessel, do not motor alongside another vessel. Do not leave the vessel on the leeward (downwind side) as the vessel may drift onto you or any fuel may spread in the water (hopefully, you will be wearing your PFD).

Reporting incidents and accidents

Where death or injury occurs (or damage when the owner of the damaged property is not present), report full particulars as soon as possible to the police station nearest to where the accident took place. Vessel operators involved in an accident must give assistance to other persons involved, without seriously endangering their own vessel, crew or passengers. They must give their name, address and identification to any person injured, or his or her representative, and to the owner of any property damaged.

Coping with emergencies

Most emergencies afloat can be avoided by good seamanship. However, they can happen on even the best-run vessels, so you need to be equipped to handle them.



Helping another vessel on fire

- Fires on other craft are indicated by large black smoke palls
- Be extremely cautious as you approach and keep to the windward side of the vessel on fire
- Remember most fires on small vessels originate from fuel, heating appliances stoves, leaking gas or fat. Fuel and gas fires spread very quickly. Even a minor spill can create an almost explosive spread of flames.

Theory of fire

There are THREE (3) elements of fire. If these elements are brought together in sufficient quantities then a fire will occur.

The elements are:

- FUEL
- HEAT
- AIR (OXYGEN)

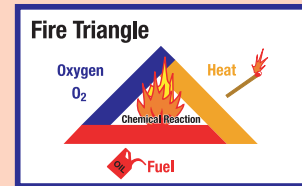

Therefore removal of any of these elements will result in the extinguishment of the fire. The element that is removed depends upon the agent used to extinguish the fire.

- REMOVAL OF FUEL – STARVING
- REMOVAL OF HEAT – COOLING
- REMOVAL OF AIR – SMOTHERING

Man overboard

When people fall overboard, the worst thing to do is jump in after them. The potential drownings immediately double. Put the motor in neutral and raise the alarm, swing the propeller quickly away from them, throw a lifebuoy ring, horseshoe or PFD to them and keep them in sight at all times.

Help the victim into the vessel, preferably over the stern, as a small vessel might capsize or take water if you try taking them in over the side. On yachts with overhanging sterns, they should be pulled in at the lowest point of freeboard.

Victims may be hurt, cold or exhausted. If they cannot help themselves, it is difficult to get them back into the vessel. Practice your 'man overboard' drill whenever possible and in all conditions.

First aid afloat

Every vessel should have a suitable first-aid kit on board. A simple kit can be purchased from a chemist shop and supplemented with sunburn cream, seasickness tablets and a pair of side cutting pliers for removing fish hooks. Make sure it contains adequate wound and burn dressings.

The kit should be kept in a sturdy, watertight plastic container, clearly marked and secured in a position where anyone on board can reach it if necessary. A booklet giving basic first-aid methods is an essential addition to the kit.

Hypothermia

The term 'hypothermia' means lowering deep-body or core temperature. 'Immersion hypothermia' is an acute type of hypothermia produced when a person is immersed in cold water. Victoria's coastal waters range from about 9.5°C in midwinter to about 22°C in midsummer. The graph shows that an adult of average build could not expect to survive more than three hours of immersion in midwinter.

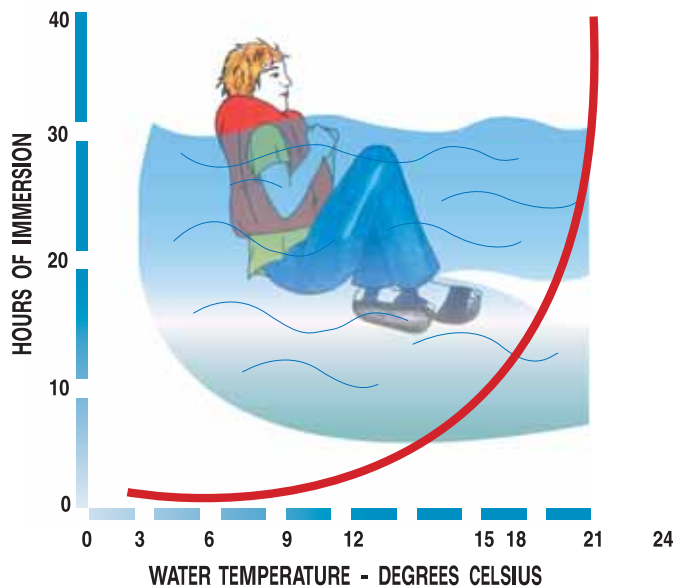

The time is very short when you consider the time lost before a search and rescue operation is under way.

The 'H.E.L.P.' (Heat Escape Lessening Posture) position pictured combats hypothermia and can be a lifesaver to people in cold water.

WARNING: the consumption of alcohol, attempting to swim or movement in the water will cause the body to expend heat very rapidly, which will hasten the onset of hypothermia.

Key points for treatment

1. Remove victim from the cold-inducing environment.
2. Protect victim from cold wind.
3. Warm the area of high heat loss, that is, head and neck, sides of chest, armpits, and groin. Do not warm, rub or massage limbs.
4. Observe the victim for deterioration in condition.
5. Manage unconscious victim by placing in the lateral position, making sure airway is clear, and performing cardiopulmonary resuscitation if necessary. Continue warming procedures.
6. Do not give alcohol or liquids.
7. Do not allow victim to walk around.
8. Seek medical aid.

Bleeding

A small cut can be treated easily by washing with a disinfectant solution and closing with a suitable dressing. **Pressure applied directly to the wound is the most effective way to stop bleeding.** Elevation of the injured part will also help to control bleeding. Occasionally, more serious injuries can occur, particularly those associated with propeller injuries involving the limbs – massive bleeding can result. This can only be controlled by the use of an arterial tourniquet, which is used only as a last resort in such serious cases.

The arterial tourniquet should be applied to the upper leg or arm, keeping well clear of the knee and arm joint. Use a broad (5.0–7.5 cm) soft roller bandage, strip of material or wide belt and encircle the limb a number of times. The arterial pulse should disappear completely below the bandage. If bleeding appears to increase rather than decrease, the tourniquet has been applied incorrectly and should be released and reapplied.

Once correctly applied, the time of application must be clearly recorded on the patient. The arterial tourniquet must not be covered by clothing or other material. It is essential to get the patient to hospital as soon as possible.

Remember that an arterial tourniquet is only used as a last resort for the control of massive, uncontrollable bleeding. In all other cases, the use of direct pressure on a bleeding point with fingers or a pad should be the first method used to try to stop bleeding.

Burns

Gently and quickly cool the burned skin immediately with plenty of cold water (sea water is excellent), but never burst blisters or cut away clothing unless the burn is from a chemical which might continue to eat into the cloth and skin beneath.

Cover the area lightly with a clean, dry, sterile burns dressing or clean cloth and keep the patient calm and quiet. Seek medical assistance as soon as possible.

Seasickness

In many cases, seasickness can be avoided if you sleep aboard the vessel the night before the voyage to let your body get used to the boat's motion. Of course, this may not be possible in small vessels. Otherwise, you can take seasickness tablets as advised by a chemist or a doctor, but be wary as some may make you drowsy.

If you feel seasick, keep busy and stay in the fresh air. Avoid the head down position, as this aggravates illness. Nibble on a dry biscuit, chew barley sugar or dried fruit. Ginger is also considered a good anti-seasickness remedy. Stay out of enclosed areas where fumes from fuel and food odours may temporarily collect.

Experienced sailors keep their diet free of rich, fatty foods and alcohol, both before going to sea and while aboard.

Exposure to the sun

Australia has the highest rate of skin cancer in the world, which is caused by exposure to ultraviolet radiation from the sun. Ultraviolet radiation is strongest between 11 am and 3 pm Daylight Saving Time and is present all year.

The boater is particularly susceptible, as reflected radiation from the water gives an additional radiation effect.

Preventative measures are important and clothing provides the best protection. Cover exposed areas with a hat that covers the face, ears and neck and wear a long-sleeved shirt. Apply a sunscreen to exposed areas with a maximum sun protector factor – SPF 15+ or above – water-resistant, broad spectrum sunscreen and a solar lipscreen. Apply the sunscreen 20 minutes before going out and reapply every two (2) hours.

For information about skin cancer protection, contact The Cancer Council Victoria on 13 11 20.

To treat sunburn, apply a cool, moist compress to the affected area but do not break any blisters. Give the patient plenty of fluids and seek medical attention quickly.

Distress signals

The following signals are some of those that are internationally recognised and indicate distress and need of assistance. Use of these signals except for the purpose indicated is prohibited.

1. Rockets or shells, throwing red stars fired one at a time at short intervals.
2. (a) A signal made by any light or sound signalling method consisting of the group in the Morse Code – SOS
(b) A signal sent by radio consisting of the spoken word – mayday.



3. A square flag having above or below it a ball or anything resembling a ball.



4. A rocket parachute flare or a hand-held flare showing a red light.



5. A smoke signal giving off orange-coloured smoke.

6. Slowly and repeatedly raising and lowering arms outstretched to each side.



7. (a) A rectangle of the internationally accepted colour orange material with a black letter V: or



- (b) A black square and circle.



8. A dye marker.

9. The international Code Signal of Distress indicated by NC.

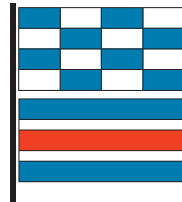

10. EPIRB (Emergency Position Indicating Radio Beacon).

11. Oar with cloth on the end.

12. Continuous sound of fog horn.

Abandoning vessel

If your vessel capsizes and you are unable to right the vessel, abandon the vessel only as a last resort. Stay close to the vessel to improve your chances of being sighted by the rescue vessel. Don't remove your PFD, if you are in the water stay together in a HUDDLE or HELP position.

Don't try to swim ashore unless it is very close and a suitable landing place exists. Distances can be deceptive. Your vessel is easier to spot in the water than a person alone.

Try to get the EPIRB and distress signals out of the capsized vessel and raise an alarm. Make yourself as visible as you can to both ships and aircraft. Put on more clothes if you are able to. They will help to keep you warm and may delay the onset of hypothermia.

If abandoning your vessel, try to get the EPIRB and distress signals out with you.

Switch on the EPIRB and leave it on until told to turn it off.



If you do capsize, stay with your boat until help arrives. Your boat will be more visible than an individual in the water.

Rescue by helicopter

The helicopter is a fast, efficient method of recovering or deploying personnel to aid injured or stricken persons aboard vessels or in the sea.

The search for a stricken vessel can pose a problem if direct communications cannot be established. An EPIRB is the ideal method of location; smoke flares, and/or a 'V' sheet will also aid identification.

For easier, safer recovery, it is preferable for a helicopter to carry out any winching operation into wind. For ease of operation, the vessel should be under way and steering 20 to 30 degrees to port or starboard off the relative wind line. This will allow the aircraft to format on the vessel, giving the pilot and crew better visibility, and ensuring any downwash will lie behind the vessel and aircraft.

Recovery from a disabled vessel requires a technique where the helicopter is required to maintain station over the target. To prepare, all loose articles above deck should be securely stowed or lashed down and a clear area prepared before the arrival of the aircraft.

The winch (or rescue line) must never be attached to the vessel.

It can literally pull the aircraft from the sky, particularly in rough seas. The increased danger of snagging a winch cable in these circumstances must also be guarded against.

Chapter 3 sample test questions

- 1 **Q** **When should the word 'mayday' be used three times at the start of a radio message?**
 - A When a vessel has broken down and requires assistance.
 - B When a vessel is in grave and immediate danger.
 - C To introduce a navigational warning.

- 2 **Q** **What does the phrase 'pan pan' indicate when said three times at the start of a radio message?**
 - A A very urgent message follows concerning the safety of a vessel or person.
 - B A vessel is in grave and immediate danger.
 - C A navigational warning is about to be announced.

- 3 **Q** **You call a distress message on your radio because your vessel is in grave and immediate danger. After using the word 'mayday' three times, what two important pieces of information should you next provide in your call?**
 - A Your personal name and vessel name.
 - B The name (or other identification) of your vessel and your position.
 - C Weather conditions and your position.

- 4 Q Which of the following is not a distress signal?**
- A** A red flare.
B A green flare.
C Slowly and repeatedly raising and lowering outstretched arms.
- 5 Q A person falls overboard from your vessel while it is under way. What should you do?**
- A** Swing the propeller away from them, throw a lifesaving device to them and keep them in sight at all times.
B You or another passenger immediately jump overboard with lifesaving devices.
C Put the motor into reverse and back up to the person.
- 6 Q When a fire occurs onboard your vessel you should immediately do what?**
- A** Raise the alarm then manoeuvre your vessel to minimise the wind from fanning the flames and fight the fire.
B Open all the hatches.
C Motor over to another vessel to get help.
- 7 Q Your vessel's motor cuts out unexpectedly and you are unable to restart it. Your first reaction should be:**
- A** Fire flares.
B Make sure everyone on board is wearing a PFD, then assess your options for raising the alarm.
C Swim for shore.
- 8 Q Your vessel is in immediate and grave danger of sinking and you are about to fire a distress signal to attract the attention of nearby vessels. As it is night, you should use the following type of flare:**
- A** Red flare.
B White flare.
C Orange smoke flare.
- 9 Q When treating a person who has been immersed in cold water for a lengthy period and they are clearly suffering from hypothermia (reduced deep-body or core temperature), you should first:**
- A** Give them alcohol and seek medical aid.
B Give them warm liquids and seek medical aid.
C Remove the person from the cold-inducing environment and protect them from the cold wind.
- 10 Q You have an emergency on your vessel and you assess that you need to signal for assistance. Would you fire flares:**
- A** As soon as you realise you need assistance.
B Every hour.
C When you see an aircraft, or when people on shore or in other boats are in visual range.

Answers

- Q1. B Q2. A Q3. B Q4. B Q5. A Q6. A Q7. B Q8. A**
Q9. C Q10. C

CHAPTER 4.

PERSONAL WATERCRAFT (PWC)

PWC describes an aquascooter, jet bike, jet ski, wave runner, ski free, motorised surfboard and any similar vessel that has an engine used for propulsion. They are also known as ‘powerskis’.

Regardless of the type of PWC, it is important for operators to remember that these are just another type of vessel and are required to be operated within the rules pertaining to ‘powerboats’.

However, PWCs are much more manoeuvrable than traditional powerboats and, in the wrong hands, can present a danger to the operator and to other people using our waterways.

Like any other boaters, PWC operators should make sure that they know the boating rules applicable to any waterway they intend to use and the general rules as outlined in this guide. Always read signage placed at boat ramps and on beaches and check for local rules which may also apply specifically to PWCs.

When being used to tow a waterskier/aquaplaner/wakeboarder/paraflyer, the rules for waterskiing must be followed. If in doubt, details of local operating rules can be obtained from TSV on 1800 223 022 or www.transportsafety.vic.gov.au, or from a local waterway manager.

Registration

All PWCs are required to be registered with VicRoads, acting as an agent of TSV, or through approved dealers.

The minimum size of the registration numbers is 100 mm and they must be attached on both sides of the PWC as shown in the illustrations below. The numbers must be in stark contrast to the background and be clearly visible at a reasonable distance when the vessel is operating. A current registration label must also be attached to the vessel.

These legal ‘decals’ must take preference over decals and striping provided to decorate or customise the PWC.

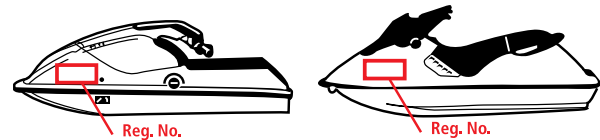

Operator licensing

Refer to licensing requirements on p. 2 of this handbook.

Education

PWC clubs and organisations will gladly introduce you to the sport and will assist with instruction and participation in recreation events.

Keep your distance

The main complaint received by marine authorities relates to the operation of PWCs close to other water users and/or the water's edge.

When operating a PWC at a speed of 5 knots or more you must keep at least:



All waters

50 metres from a person in the water; 50 metres from another vessel, including other PWCs; 100 metres from a diver's flag/buoy/vessel.



Coastal and enclosed waters

200 metres from the water's edge; 50 metres off a wharf, jetty, slipway, diving platform or boat ramp.



Inland waters

50 metres from the water's edge;
50 metres from a fixed or floating structure.

The minimum distance between vessels does not apply if the vessels are:

- engaged in bona fide training or an event organised by a recognised water sporting association
- operating within an exclusive PWC zone in which the width of water prevents the required distance being kept between vessels.

These are minimum safety distances and must be applied on all waterways unless a specific local rule provides otherwise.

PWCs must keep away from swimming and surfing beaches and from areas where other vessels may operate in close proximity, for example, at boat ramps, mooring/berthing areas, yacht races.

Noise

One of the most common complaints received about PWCs is – **noise**.

Many PWC operators tend to congregate near residential or popular recreation areas and drive around repeatedly in the same area. This noise can be irritating to people using the foreshore and to residents often some distance from the water.

Individually, most PWCs are not excessively noisy when compared to other vessels. However, if continually operated close to the shore, or when operating in groups, or when 'porpoising' or performing manoeuvres, noise levels do increase.

Don't operate a PWC in the early morning, or when winds are blowing onshore if you are in populated areas – including camp sites.

Respect the peace of other people and wildlife.

Remember: the less number of complaints, the greater the chance to enjoy the sport.

Safety equipment

The operator and passengers (including anyone being towed) must wear an approved PFD Type 1, 2 or 3 at all times.

PWCs must now also carry a waterproof buoyant torch at all times. A torch can be used to signal the shore or other vessels if you encounter difficulties.

An EPIRB is required on all vessels if operating more than 2 nm from the coast.

Waterskiing

PWCs are more often being used for waterskiing. Remember that the normal waterskiing rules apply to PWCs towing skiers, including the need to carry an appropriate observer on the PWC.

The carrying capacity of the PWC must cater for the operator, observer and any person/s being towed.

Safe speed

All vessels are required to travel at a safe speed at all times. Remember – no power means no steering control. You must always have power to maintain control. If you allow the engine to idle or shut off during operation, you lose all steering control.

The operator of a PWC must constantly monitor the speed of the vessel to ensure that a safe speed is being maintained.

Follow speed signs and buoys marking waterway zones.

Remember, spectacular stunts and manoeuvres must be done well away from other people, other vessels and the shore. If you cannot maintain the minimum distances off, you must slow down.

Avoiding accidents

The boating rules made under the *Marine Act 1988* apply to the drivers of all vessels and that includes PWC riders.

The International Regulations for Preventing Collisions apply to drivers of all vessels and that includes PWC riders.

A PWC must give way to:

- larger vessels operating in confined channels
- sailing vessels
- other vessels crossing from the right
- vessels being overtaken.



One of the most important rules is the requirement to keep a good look out at all times.

In particular, remember:

- In surf areas, swimmers may be hidden from view by waves and swell. Keep well away from areas where swimmers are likely to be present, or slow right down
- Do not cut blind corners – slow down
- If vision is affected by the sun or spray – slow down or stop
- Keep well clear of anchored or moored vessels.

In channels and narrow stretches of water, you must drive on the right hand or starboard side.

Navigation lights are required if your PWC is used on the waters between sunset and sunrise.

Safety first

- Wear an approved PFD, plus suitable footwear, goggles and gloves
- Carry a waterproof buoyant torch
- Avoid swimming areas
- Always attach the ignition cut-out safety lines
- Don't drink and ride
- Obey all boating regulations and signs
- Consider other people.

Penalties

Boating is meant to be enjoyable and no one wants to finish up in trouble when they are out having fun.

All PWC operators must have a boat operator licence with PWC endorsement to operate on any Victorian waters.

Penalties exist for those boat operators who do not want to play by the rules. On-the-spot infringements may be issued. The most common infringements include:

Owners

Unregistered vessel or no registration numbers.

Riders

Excessive speed, failing to keep minimum distances off or failing to wear approved PFDs. Of course, in the case of serious safety offences, court action or loss of licence can also occur.

Enjoying a PWC is one of our fastest growing recreation activities. As a responsible rider, you should follow the rules outlined in this handbook.

If you need any information:

Rules Transport Safety Victoria
Parks Victoria

Tel. 1800 223 022
Tel. 13 19 63

What does it mean to be a safe and courteous rider?



MAXIMUM SPEED

- Within 50 m of swimmers, other vessels and fixed or floating structures
- Within 100 m of divers/divers' flag
- Within 50 m of water's edge (inland)
- Within 200 m of water's edge (coastal and enclosed)



HOLDING A BOAT LICENCE WITH PWC ENDORSEMENT



WEARING AN APPROVED PERSONAL FLOTATION DEVICE



CARRYING A WATERPROOF BUOYANT TORCH



DON'T DRINK AND OPERATE A PWC



RESPECTING THE PEACE – NOISE ANNOYS



KEEPING A GOOD LOOK OUT AT ALL TIMES

Chapter 4 sample test questions

1 Q Is a person aged between 12–15 years able to obtain a PWC endorsement?

A No.

B Yes, but only to operate up to 10 knots unsupervised and between 10 and 20 knots if accompanied by a licensed person who is at least 16 years of age, and during daylight hours only.

C Yes, to operate at any speed during daylight hours only.

2 Q Can a person under the age of 12 be licensed to operate a PWC?

A No.

B Yes, but only up to 10 knots unsupervised and between 10 and 20 knots if accompanied by a licensed person who is at least 16 years of age, and during daylight hours only.

C Yes, but during daylight hours only.

3 Q When operating a PWC at a speed of 5 knots or more on all Victorian waters, how far must you keep from a person in the water or from another vessel, including other PWCs?

A 100 m.

B 50 m.

C 30 m.

4 Q When operating a PWC at a speed of 5 knots or more on Victorian inland waters, how far must you keep from the water's edge?

A 30 m.

B 50 m.

C 200 m.

5 Q When operating a PWC at a speed of 5 knots or more on Victorian coastal waters and ports, how far must you keep from the water's edge?

A 50 m.

B 100 m.

C 200 m.

6 Q When operating a PWC at a speed of 5 knots or more on Victorian coastal and inland waters, how far must you keep from a diver's flag/buoy/vessel?

A 30 m.

B 50 m.

C 100 m.

7 Q Noise is one of the most common complaints received about PWCs. Which of the following would assist in reducing the potential for noise complaints in populated areas?

- A** Don't operate a PWC early in the morning or when winds are blowing onshore.
- B** Avoid operating in groups.
- C** All of the above.

8 Q When using a PWC for waterskiing:

- A** The PWC is exempt from the rules applying to other powerboats towing a waterskier.
- B** The PWC is exempt from the rules applying to other powerboats towing a waterskier, except that an appropriate observer must be carried on the PWC.
- C** The PWC must comply with the rules applying to other powerboats towing a waterskier, including carrying an appropriate observer on the PWC.

9 Q What minimum seating capacity must a PWC have before it can be used to tow a waterskier?

- A** Capacity for the operator.
- B** Capacity for operator and an observer.
- C** Capacity for the operator, an observer and anyone being towed.

10 Q Your PWC has been disabled. How can you highlight that you are in distress?

- A** Swim to shore for assistance.
- B** Slowly and repeatedly raising and lowering arms outstretched to each side.
- C** Wave your PFD above your head.

11 Q The registration numbers of a PWC must be a minimum size of 100 mm and be:

- A** Displayed on both sides of the bow.
- B** Displayed on the central arm or stern of the vessel.
- C** Displayed on one side of the vessel only.

- 12 Q What safety equipment is required onboard a PWC within 2 nm of the coast?**
- A** A PFD for persons under 16yrs of age being towed.
 - B** An approved PFD worn by everyone on board and being towed, and a waterproof buoyant torch.
 - C** A PFD for children on board and an anchor.
- 13 Q A PWC must give way to:**
- A** Larger vessels, in confined channels where the vessels' manoeuvrability might be limited, and sailing vessels.
 - B** Other vessels crossing from the right.
 - C** All of the above.
- 14 Q What should be your immediate reaction if your vision is suddenly affected by sun or spray when manoeuvring at high speed?**
- A** Slow down or stop.
 - B** Continue manoeuvring at speed in anticipation that you will regain your vision.
 - C** Continue manoeuvring at speed to quickly find the right direction to minimise spray and effect of the sun.
- 15 Q Continuous driving of a PWC close to residential, picnic or recreation areas should be avoided because:**
- A** It increases the chances of the sport being banned from that waterway.
 - B** It creates an image of irresponsible behaviour.
 - C** All of the above.
- 16 Q If you are proceeding up a narrow channel, river or harbour entrance where it is not possible to maintain the minimum distance off other vessels or swimmers:**
- A** You can travel at whatever speed you like.
 - B** You must slow down to 5 knots or less.
 - C** You need only slow down if there is danger of collision with another vessel or swimmer.
- 17 Q You are operating a PWC at 35 knots when another PWC stops 50 m ahead. To avoid a collision you should:**
- A** Decelerate and turn the steering to alter course.
 - B** Maintain enough power to initiate a turn.
 - C** Jump off.

18 Q When nearing the shore and there are people in the water, what must you do?

- A** Maintain power for manoeuvrability at a speed of less than 5 knots.
- B** Speed up to get past the people quickly.
- C** Turn your engine off and glide to the beach.

19 Q When is an unlicensed person able to legally drive a PWC in navigable waters?

- A** When riding with another licensed operator.
- B** When test riding prior to purchase.
- C** Never. The rider must always hold a valid licence with a PWC endorsement.

Answers

Q1. B Q2. A Q3. B Q4. B Q5. C Q6. C Q7. C Q8. C Q9. C
Q10. B Q11. A Q12. B Q13. C Q14. A Q15. C
Q16. B Q17. B Q18. A Q19. C

USEFUL LINKS

State Maritime Authorities

Transport Safety Victoria
www.transportsafety.vic.gov.au

NSW Maritime
www.maritime.nsw.gov.au

Department of Transport – South Australia
www.transport.sa.gov.au

Department of Planning and Infrastructure
– Western Australia
www.dpi.wa.gov.au/imarine

Department of Infrastructure, Planning
and Environment – Northern Territory
www.ipe.nt.gov.au/whatwedo/marinesafety

Maritime Safety Queensland
www.msq.qld.gov.au

Marine and Safety Tasmania
www.mast.tas.gov.au

National Maritime Authorities

Australian Maritime Safety Authority
www.amsa.gov.au

National Marine Safety Committee
www.nmsc.gov.au

Port Authorities

Port of Melbourne Corporation
www.portofmelbourne.com

Gippsland Ports
www.gippslandports.vic.gov.au

Port of Geelong
www.regionalchannels.vic.gov.au

Port of Hastings
www.portofhastings.vic.gov.au

Port of Portland
www.portofportland.com.au

Government Links

Bureau of Meteorology
www.bom.vic.gov.au

Play it Safe by the Water
www.watersafety.vic.gov.au

Parks Victoria
www.parkweb.vic.gov.au

Safe Boating
www.safeboating.org.au

VICROADS CUSTOMER SERVICE CENTRES

Trading hours

8.30 am–4.30 pm
Monday to Thursday

8.30 am–5.00 pm
Friday

All telephone enquiries

13 11 71

8.30 am–5.00 pm
Monday to Saturday

Metropolitan Offices

BROADMEADOWS

Cnr Pearcedale Parade
and Johnstone Street
Broadmeadows 3047

BUNDOORA

8 Graduate Road
University Hill
Bundoora 3083

BURWOOD EAST

12 Lakeside Drive
Burwood East 3151

CAMBERWELL

3 Prospect Hill Road
Camberwell 3124

CARLTON

459 Lygon Street
Carlton 3053

DANDENONG

72-74 Greens Road
Dandenong South 3175

DROMANA

Shop 11
Dromana Central
143 Point Nepean Road
Dromana 3936

FRANKSTON

71 Hartnett Drive
Seaford 3198

GEELONG

180 Fyans Street
Geelong South 3220

HOPPERS CROSSING

52-64 Old Geelong Road
Hoppers Crossing 3029

MELTON

C/o Shire Offices
232 High Street
Melton 3337

OAKLEIGH SOUTH

1 Eskay Road
South Oakleigh 3167

SUNBURY

Shire Offices
36 Macedon Street
Sunbury 3429

SUNSHINE

499 Ballarat Road
Sunshine 3020

Country Offices

ARARAT

Shop 2
56 High Street
Ararat 3377

BAIRNSDALE

535 Princes Highway
Bairnsdale 3875

BALLARAT

88 Learmonth Road
Wendouree 3355

BENALLA

50–52 Clarke Street
Benalla 3550

BENDIGO

57 Lansell Street
Bendigo 3550

COBRAM

Shire Offices
44 Station Street
Cobram 3644

COLAC

Princes Highway
Colac West 3250

ECHUCA

5 Mundarra Road
Echuca 3564

HAMILTON

Riley Street
Hamilton 3300

HORSHAM

14 O'Callaghans Parade
Horsham 3400

KYNETON

2 Beauchamp Street
Kyneton 3444

LEONGATHA

Anderson Street
Leongatha 3953

MARYBOROUGH

Shire Offices
Neill Street
Maryborough 3465

MILDURA

109–111 Orange Avenue
Mildura 3500

MORWELL

87 Princes Drive
Morwell 3840

PORTLAND

114a Percy Street
Portland 3305

SALE

28 Princes Highway
Sale 3850

SEYMOUR

5 Crawford Street
Seymour 3660

SHEPPARTON

231–239 Corio Street
Shepparton 3630

SWAN HILL

70 Nyah Road
Swan Hill 3585

WANGARATTA

6–8 Handley Street
Wangaratta 3677

WARRAGUL

Unit 5
131 North Road
Warragul 3820

WARRNAMBOOL

29 Jamieson Street
Warrnambool 3280

WODONGA

82–86 Elgin Street
Wodonga 3690

BOATING SAFETY IS NO ACCIDENT